

WHELEN[®]

ENGINEERING COMPANY INC.

51 Winthrop Road
Chester, Connecticut 06412-0684
Phone: (860) 526-9504
Internet: www.whelen.com
Sales e-mail: autosale@whelen.com
Customer Service e-mail: custserv@whelen.com

Installation Guide:
Model L21 LED Beacon
(Encapsulated)

Warnings to Installers

Whelen's emergency vehicle warning devices must be properly mounted and wired in order to be effective and safe. Read and follow all of Whelen's written instructions when installing or using this device. Emergency vehicles are often operated under high speed stressful conditions which must be accounted for when installing all emergency warning devices. Controls should be placed within convenient reach of the operator so that they can operate the system without taking their eyes off the roadway. Emergency warning devices can require high electrical voltages and/or currents. Properly protect and use caution around live electrical connections. Grounding or shorting of electrical connections can cause high current arcing, which can cause personal injury and/or vehicle damage, including fire. Many electronic devices used in emergency vehicles can create or be affected by electromagnetic interference. Therefore, after installation of any electronic device it is necessary to test all electronic equipment simultaneously to insure that they operate free of interference from other components within the vehicle. Never power emergency warning equipment from the same circuit or share the same grounding circuit with radio communication equipment. All devices should be mounted in accordance with the manufacturer's instructions and securely fastened to vehicle elements of sufficient strength to withstand the forces applied to the device. Driver and/or passenger air bags (SRS) will affect the way equipment should be mounted. This device should be mounted by permanent installation and within the zones specified by the vehicle manufacturer, if any. Any device mounted in the deployment area of an air bag will damage or reduce the effectiveness of the air bag and may damage or dislodge the device. Installer must be sure that this device, its mounting hardware and electrical supply wiring does not interfere with the air bag or the SRS wiring or sensors. Mounting the unit inside the vehicle by a method other than permanent installation is not recommended as unit may become dislodged during swerving; sudden braking or collision. Failure to follow instructions can result in personal injury. Whelen assumes no liability for any loss resulting from the use of this warning device. **PROPER INSTALLATION COMBINED WITH OPERATOR TRAINING IN THE PROPER USE OF EMERGENCY WARNING DEVICES IS ESSENTIAL TO INSURE THE SAFETY OF EMERGENCY PERSONNEL AND THE PUBLIC.**

Warnings to Users

Whelen's emergency vehicle warning devices are intended to alert other operators and pedestrians to the presence and operation of emergency vehicles and personnel. However, the use of this or any other Whelen emergency warning device does not guarantee that you will have the right-of-way or that other drivers and pedestrians will properly heed an emergency warning signal. Never assume you have the right-of-way. It is your responsibility to proceed safely before entering an intersection, driving against traffic, responding at a high rate of speed, or walking on or around traffic lanes. Emergency vehicle warning devices should be tested on a daily basis to ensure that they operate properly. When in actual use, the operator must ensure that both visual and audible warnings are not blocked by vehicle components (i.e.: open trunks or compartment doors), people, vehicles, or other obstructions. It is the user's responsibility to understand and obey all laws regarding emergency warning devices. The user should be familiar with all applicable laws and regulations prior to the use of any emergency vehicle warning device. Whelen's audible warning devices are designed to project sound in a forward direction away from the vehicle occupants. However, because sustained periodic exposure to loud sounds can cause hearing loss, all audible warning devices should be installed and operated in accordance with the standards established by the National Fire Protection Association.

Safety First

This document provides all the necessary information to allow your Whelen product to be properly and safely installed. Before beginning the installation and/or operation of your new product, the installation technician and operator must read this manual completely. Important information is contained herein that could prevent serious injury or damage.

⚠ WARNING: This product can expose you to chemicals including Methylene Chloride which is known to the State of California to cause cancer, and Bisphenol A, which is known to the State of California to cause birth defects or other reproductive harm. For more information go to www.P65Warnings.ca.gov.

- **Proper installation of this product requires the installer to have a good understanding of automotive electronics, systems and procedures.**
- **Whelen Engineering requires the use of waterproof butt splices and/or connectors if that connector could be exposed to moisture.**
- **Any holes, either created or utilized by this product, should be made both air- and watertight using a sealant recommended by your vehicle manufacturer.**
- **Failure to use specified installation parts and/or hardware will void the product warranty.**
- **If mounting this product requires drilling holes, the installer MUST be sure that no vehicle components or other vital parts could be damaged by the drilling process. Check both sides of the mounting surface before drilling begins. Also de-burr the holes and remove any metal shards or remnants. Install grommets into all wire passage holes.**
- **If this manual states that this product may be mounted with suction cups, magnets, tape or Velcro®, clean the mounting surface with a 50/50 mix of isopropyl alcohol and water and dry thoroughly.**
- **Do not install this product or route any wires in the deployment area of your air bag. Equipment mounted or located in the air bag deployment area will damage or reduce the effectiveness of the air bag, or become a projectile that could cause serious personal injury or death. Refer to your vehicle owner's manual for the air bag deployment area. The User/Installer assumes full responsibility to determine proper mounting location, based on providing ultimate safety to all passengers inside the vehicle.**
- **For this product to operate at optimum efficiency, a good electrical connection to chassis ground must be made. The recommended procedure requires the product ground wire to be connected directly to the NEGATIVE (-) battery post (this does not include products that use cigar power cords).**
- **If this product uses a remote device for activation or control, make sure that this device is located in an area that allows both the vehicle and the device to be operated safely in any driving condition.**
- **Do not attempt to activate or control this device in a hazardous driving situation.**
- **This product contains either strobe light(s), halogen light(s), high-intensity LEDs or a combination of these lights. Do not stare directly into these lights. Momentary blindness and/or eye damage could result.**
- **Use only soap and water to clean the outer lens. Use of other chemicals could result in premature lens cracking (crazing) and discoloration. Lenses in this condition have significantly reduced effectiveness and should be replaced immediately. Inspect and operate this product regularly to confirm its proper operation and mounting condition. Do not use a pressure washer to clean this product.**
- **It is recommended that these instructions be stored in a safe place and referred to when performing maintenance and/or reinstallation of this product.**
- **FAILURE TO FOLLOW THESE SAFETY PRECAUTIONS AND INSTRUCTIONS COULD RESULT IN DAMAGE TO THE PRODUCT OR VEHICLE AND/OR SERIOUS INJURY TO YOU AND YOUR PASSENGERS!**

L21: This Beacon has fully encapsulated electronics that are impervious to damage from moisture and vibration. Some units feature an automatic photocell High Power override. This beacon also features Scan-Lock™ which allows you to choose between 25 available flash patterns. You have 6 available mounting options (not all included with beacon): mirror mount, permanent mount, pipe mount, J-hook mount, magnetic mount and Vacuum mount. (Magnetic and Vacuum mount do not include SYNC.) All models are SAE certified.

IMPORTANT! All beacons in this manual should be fused at 3 AMPS.

Electrical Specifications

Power	12V	24V
Input Voltage	12.8 VDC ± 20%	25.6 VDC ± 20%
Input Current	Peak: 1.5 amps Avg: 0.60 amps	Peak: 0.75 amps Avg: 0.30 amps
ScanLock™ CTRL	12.8 VDC +/- 20%	25.6 VDC +/- 20%
ScanLock™ Current	20ma	10ma
Default Flash Pattern	SignalAlert™ / Sim	SignalAlert™ / Sim

IMPORTANT! Always be sure the drain hole (located on the bottom of the base) is facing the rear of the vehicle after mounting.

WARNING: All customer supplied wires that connect to the positive terminal of the battery must be sized to supply at least 125% of the maximum operating current and FUSED at the battery to carry the load. DO NOT USE CIRCUIT BREAKERS WITH THIS PRODUCT!

Wiring:

Listed below are the wire designations for the L21 beacon. To extend the beacons wires, use the wire gauge indicated.

WIRE COLOR	WIRE GAUGE	FUNCTION
RED	18 AWG	Positive
BLACK	18 AWG	Ground
GREY	18 or 22 AWG	SYNC
WHITE-VIOLET	18 or 22 AWG	Scan-Lock™

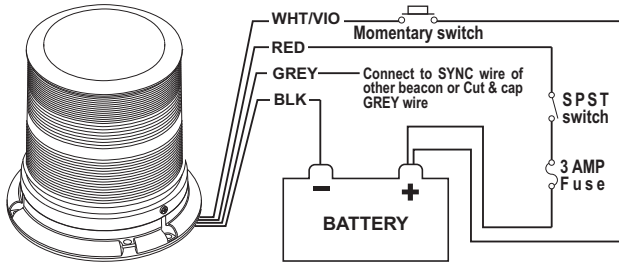

Mounting:

“J” HOOK MOUNT:

This beacon is equipped to handle the “J” hook mount available on some beacons. Be sure to use the correct “J” hook mounting holes (Fig. 1).

PERMANENT MOUNT:

1. Use the base as a template and mark the three mounting holes off onto the mounting surface. Remove base. In the center between the three mounting holes, mark the location of the wire access hole.

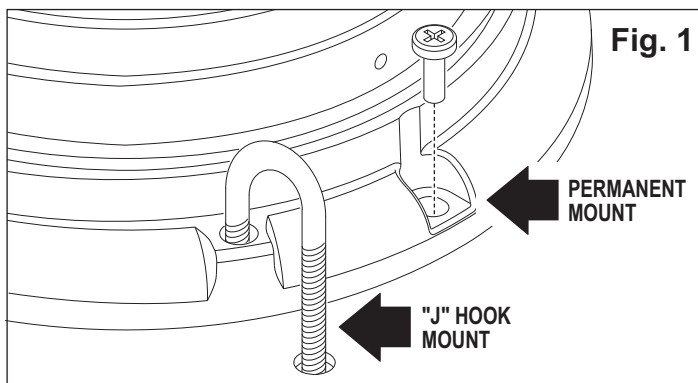

2. Drill the mounting holes with a #16 drill bit. Drill the wire access hole using a 3/8” drill bit. Remove any burrs from the wire access hole and it is also recommended that you install a rubber grommet (*customer supplied*) into the wire hole to protect the wires.
3. A base seal is used between the beacon base and mounting surface.
4. Feed the wires first through the base seal and then through the cable access hole and place the base (*with seal*) on the mounting surface (*while lining up the mounting holes in the base with the mounting holes you drilled into the mounting surface*). Secure the beacon firmly to the mounting surface with the supplied mounting screws.

1 INCH (NPT) PIPE MOUNT:

Threading for a 1 inch (NPT) pipe mounting is precast in the base.

1. Feed power cable through the 1 inch pipe and connect the cable to the wires of the beacon.
2. Screw the beacon into the threads on the 1” pipe, taking precaution not to damage the connected power wires. Do not tighten base too hard as not to damage threads on base.

TEMPORARY MOUNT:

IMPORTANT WARNING: The use of any magnetically mounted warning device on the outside of a vehicle in motion is not recommended and is at the sole risk and responsibility of the user.

Magnetic/suction: Thoroughly clean the proposed mounting surface prior to mounting. For suction cup mounting, wipe the suction cup clean, place the beacon onto its mounting surface and apply gentle pressure to ensure a good seal has been achieved. Magnetic/Suction Cups mount the same as standard suction cups but are best suited to a flat, steel surface.

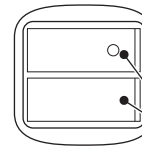

NOTE: The cigar cord adaptor is equipped with an 8 Amp fuse. Use a replacement fuse with an identical value.
Switch Functions:
SW1 = ON/OFF
SW2 = Scan-Lock™ / Momentary (12 volt model only)

Magnetic: Place the beacon onto the mounting surface and plug it into the vehicle cigar lighter. Magnetic mount models do not offer SYNC.

Operation: SYNC:

To SYNC two beacons, configure both beacons to display the same Phase 1 (Simultaneous) pattern. Turn the power off and connect the GREY wire from each beacon together. When the beacons are activated their patterns will be synchronized. To configure two beacons to alternate their patterns, advance the pattern of either beacon to Phase 2 (Alternating) of the current pattern. (Not available on cigar plug models)

Hi/Low Power: Photocell

If this beacon is equipped with photocell Hi-Low, the beacon will automatically step down to low power at night. This feature is optional.

Programming / Scan-Lock™ / White-Violet:

To cycle forward through all patterns: With the beacon switched on, apply Positive (+) voltage to the WHT-VIO wire for less than 1 second and release. **To cycle backward through all patterns:** Apply Positive (+) voltage to the WHT-VIO wire for more than 1 second and release.

To set a pattern as default: When the desired pattern is displayed, allow it to run for more than 5 seconds. The beacon will now display this pattern when activated.

To reset to the factory default pattern: Turn off power. Now, while applying Positive (+) voltage to the WHITE-VIOLET wire, turn power on.

NOTE: Cigar cord models have a momentary switch on the plug to control Scan-Lock™ as well as an On/Off switch.

IMPORTANT WARNING!
CAUTION! DO NOT LOOK DIRECTLY AT THESE LEDS WHILE THEY ARE ON. MOMENTARY BLINDNESS AND/OR EYE DAMAGE COULD RESULT!

Available Scan-Lock™ Patterns:

Flash Pattern Phase
 1 - SignalAlert™ 75 Phase 1
 2 - SignalAlert™ 75 Phase 2
 3 - CometFlash® 75 Phase 1
 4 - CometFlash® 75 Phase 2

5 - DoubleFlash 75 Phase 1
 6 - DoubleFlash 75 Phase 2
 7 - SingleFlash 75 Phase 1
 8 - SingleFlash 75 Phase 2
 9 - ComAlert™ 75 Phase 1

10 - ComAlert™ 75 Phase 2
 11 - LongBurst™ 75 Phase 1
 12 - LongBurst™ 75 Phase 2
 13 - PingPong™ 75 Phase 1
 14 - PingPong™ 75 Phase 2

15 - SingleFlash 60
 16 - SingleFlash 90
 17 - SingleFlash 120
 18 - SingleFlash 300
 19 - DoubleFlash 150

20 - ComAlert™ 150
 21 - ActionFlash™ 1
 22 - ActionFlash™ 2
 23 - ModuFlash™
 24 - ActionScan™
 25 - Steady

IMPORTANT! It is the responsibility of the installation technician to make sure that the installation and operation of this product will not interfere with or compromise the operation or efficiency of any vehicle equipment! Before returning the vehicle to active service, visually confirm the proper operation of this product, as well as all vehicle components/equipment.

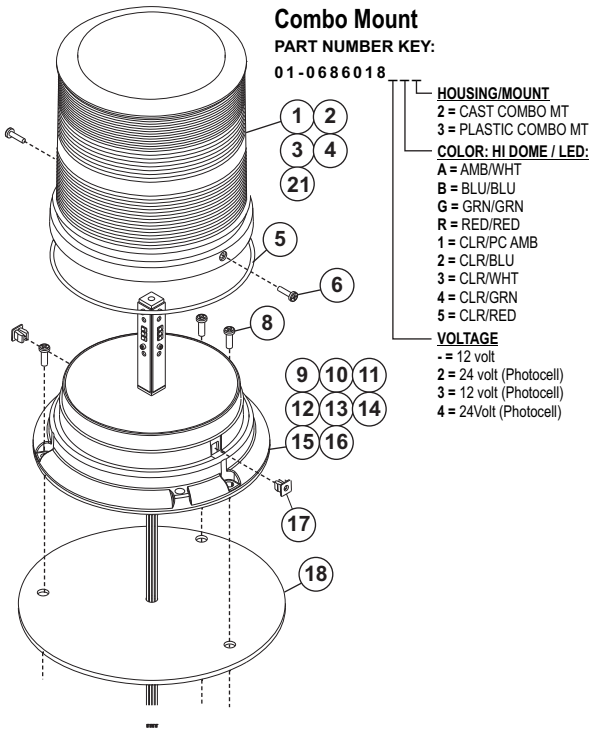

QTY	QTY	QTY	QTY	QTY	QTY	QTY	QTY	QTY	ITEM	PART NUMBER	DESCRIPTION	
									*	01-0686018-2	L21E LED BEACON, COMBO, 12V, CAST	
									*	01-06860182-2	L21E LED BEACON, COMBO, 24V, CAST	
									*	01-0686018-3	L21E LED BEACON, COMBO, 12V, PLASTIC	
									*	01-06860182-3	L21E LED BEACON, COMBO, 24V, PLASTIC	
									*	01-06860183-2	L21E LED BEACON / COMBO / 12V CAST / PHOTOCCELL	
									*	01-06860184-2	L21E LED BEACON / COMBO / 24V CAST / PHOTOCCELL	
	*								*	01-06860183-3	L21E LED BEACON / COMBO / 12V PLASTIC / PHOTOCCELL	
*									*	01-06860184-3	L21E LED BEACON / COMBO / 24V PLASTIC / PHOTOCCELL	
A/R	A/R	A/R	A/R	A/R	A/R	A/R	A/R	A/R	1	68-2180483-20	LENS OPTIC, MODEL #1079 BLUE HI	
A/R	A/R	A/R	A/R	A/R	A/R	A/R	A/R	A/R	2	68-2180483-40	LENS OPTIC, MODEL #1079 GREEN HI	
A/R	A/R	A/R	A/R	A/R	A/R	A/R	A/R	A/R	3	68-2180483-10	LENS OPTIC, MODEL #1079 AMBER HI	
A/R	A/R	A/R	A/R	A/R	A/R	A/R	A/R	A/R	4	68-2180483-30	LENS OPTIC, MODEL #1079 CLEAR HI	
1	1	1	1	1	1	1	1	1	5	38-0443007-00	O RING / 4.724 ID X .079 THK 70 DUROMETER BLK	
2	2	2	2	2	2	2	2	2	6	15-065419-080	SCREW / #6 X 1/2 PPH PLASTIC-LOC	
1	1	1	1	1	1	1	1	1	7	10-0323283-13	LABEL / MODEL L21E	
3	3	3	3	3	3	3	3	3	8	15-101416-100	SCREW / 10 X 5/8 PPHSMS 410 SS	
-	-	-	-	-	-	-	-	-	1	9	01-0286019211	L21E 12V AMBER, CAST
-	-	-	-	-	-	-	-	-	1	10	01-0286019212	L21E 24V AMBER, CAST
-	-	-	-	-	-	-	-	-	1	11	01-0286019311	L21E 12V AMBER, PLASTIC
-	-	-	-	-	-	-	-	-	1	12	01-0286019312	L21E 24V AMBER, PLASTIC
-	-	-	-	-	-	-	-	-	1	13	01-0286019213	L21E 12V AMBER, CAST / PHOTOCCELL
-	-	-	-	-	-	-	-	-	1	14	01-0286019214	L21E 24V WHITE, CAST / PHOTOCCELL
-	1	-	-	-	-	-	-	-	1	15	01-0286019313	L21E 12V AMBER PLASTIC / PHOTOCCELL
1	-	-	-	-	-	-	-	-	1	16	01-0286019314	L21E 24V WHITE PLASTIC / PHOTOCCELL
-	-	2	2	-	-	2	2	2	17	13-062C40-16J	SCREW / GROMMET #6 #8 FASTEX	
1	1	1	1	1	1	1	1	1	18	38-0241596-00	SEAL / BASE MODEL 2000 SERIES B	
1	1	1	1	1	1	1	1	1	19	10-0323189-00	LABEL / NASCAR BAR LOGO / not shown	
1	1	1	1	1	1	1	1	1	20	10-0543601-___	LABEL / M-N P-N S-N / not shown	
A/R	A/R	A/R	A/R	A/R	A/R	A/R	A/R	A/R	21	68-2180483-50	LENS OPTIC, MODEL #1079 RED HI	

QTY	QTY	QTY	QTY	ITEM	PART NUMBER	DESCRIPTION
				*	01-0686018-1	L21E LED BEACON 12V PLASTIC / MAG MT.
				*	01-06860183-1	L21E LED BEACON 12V PLASTIC / MAG MT. / PHOTOCCELL
				*	01-0686018-4	L21E LED BEACON 12V PLASTIC / VAC MT.
				*	01-06860183-4	L21E LED BEACON 12V PLASTIC / VAC MT. / PHOTOCCELL
A/R	A/R	A/R	A/R	1	68-2180483-10	LENS OPTIC / MODEL #1079 AMBER HI
A/R	A/R	A/R	A/R	2	68-2180483-30	LENS OPTIC / MODEL #1079 CLEAR HI
A/R	A/R	A/R	A/R	3	68-2180483-20	LENS OPTIC / MODEL #1079 BLUE HI
A/R	A/R	A/R	A/R	4	68-2180483-40	LENS OPTIC / MODEL #1079 GREEN HI
1	1	1	1	5	38-0443007-00	O RING / 4.724 ID X .079 THK 70 DUROMETER BLK
2	2	2	2	6	15-065419-080	SCREW / #6 X 1/2 PPH PLASTIC-LOC
1	1	1	1	7	10-0323283-13	LABEL / MODEL L21E / not shown
-	1	-	1	8	01-02860191-1	SUB ASSY BALLAST / L21E 12V PLASTIC / CIGAR PLUG
1	-	1	-	9	01-02860191-3	S. ASSY / BALLAST / L21E 12V PLAST. / CIGAR PLUG / PHOTOCCELL
1	1	1	1	10	10-0543601-___	LABEL / M-N P-N S-N / not shown
-	-	1	1	11	66-0421273-00	TAPE / MOUNTING / 90LB MAGNET
-	-	1	1	12	65-0010192-00	MAGNET / X-80
-	-	1	1	13	38-0143340-00	PAD / MOUNTING / MAGNETIC MOUNT
1	1	-	-	16	07-764648-023	PLATE / ADAPTER MAG/SUCTION CUP
2	2	-	-	17	15-081416-080	SCREW / 8 X 1/2 PPHSMS
1	1	-	-	18	08-1583927-05	SUCTION CUP / MAGNET MOUNT
1	1	-	-	19	16-1302820-06	WASHER / FLAT 1/4" 7/8 OD SS
1	1	-	-	20	14-130216-120	1/4-20 X 3/4 PPHMS SS SCREW
A/R	A/R	A/R	A/R	21	68-2180483-50	LENS OPTIC / MODEL #1079 RED HI

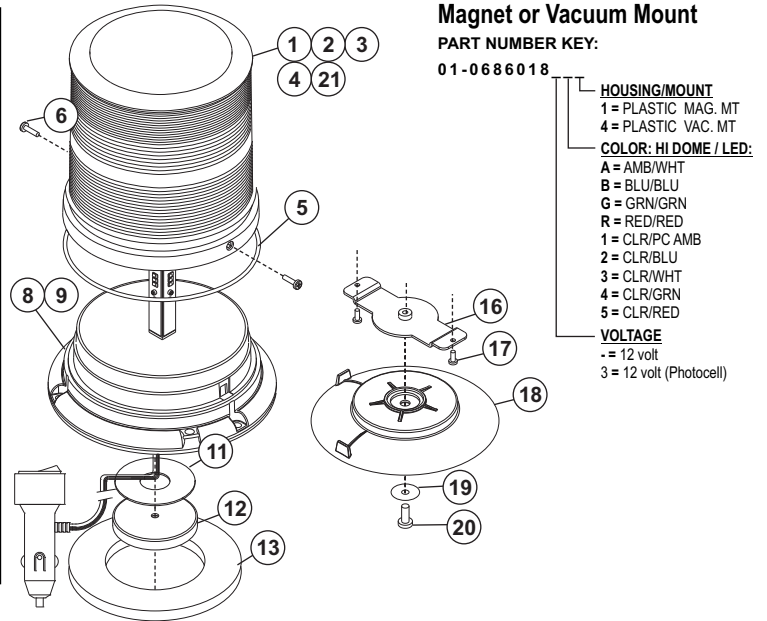

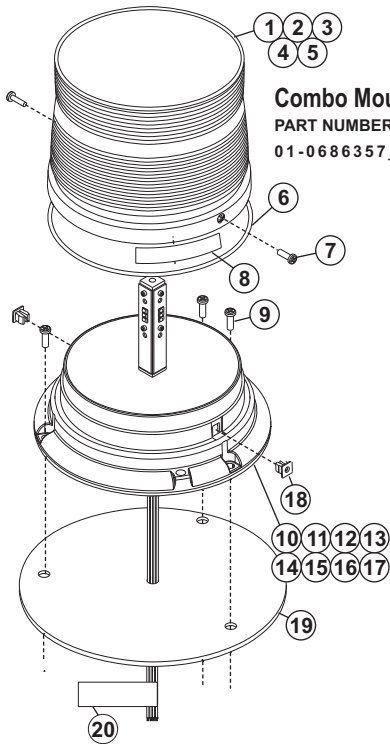

Combo Mount
PART NUMBER KEY:
01-0686357

- HOUSING/MOUNT**
2 = CAST COMBO MT
3 = PLASTIC COMBO MT
- COLOR: LO DOME / LED:**
A = AMB/WHT
B = BLU/BLU
G = GRN/GRN
R = RED/RED
1 = CLR/PC AMB
2 = CLR/BLU
3 = CLR/WHT
4 = CLR/GRN
5 = CLR/RED
- VOLTAGE**
- = 12 volt
2 = 24 volt
3 = 12 volt (Photocell)
4 = 24V (Photocell)

QTY	QTY	QTY	QTY	QTY	QTY	QTY	QTY	QTY	ITEM	PART NUMBER	DESCRIPTION
								*		01-0686357-2	L21E LED BEACON / COMBO / 12V CAST
								*		01-0686357-2	L21E LED BEACON / COMBO / 24V CAST
					*					01-0686357-3	L21E LED BEACON / COMBO / 12V PLASTIC
					*					01-0686357-3	L21E LED BEACON / COMBO / 24V PLASTIC
					*					01-0686357-2	L21E LED BEACON / COMBO / 12V CAST / PHOTO.
					*					01-0686357-2	L21E LED BEACON / COMBO / 24V CAST / PHOTO.
	*									01-0686357-3	L21E LED BEACON / COMBO / 12V PLASTIC / PHOTO.
*										01-0686357-3	L21E LED BEACON / COMBO / 24V PLASTIC / PHOTO.
A/R	A/R	A/R	A/R	A/R	A/R	A/R	A/R	A/R	1	68-2180452-10	LENS OPTIC / AMBER / LOW
A/R	A/R	A/R	A/R	A/R	A/R	A/R	A/R	A/R	2	68-2180452-20	LENS OPTIC / BLUE / LOW
A/R	A/R	A/R	A/R	A/R	A/R	A/R	A/R	A/R	3	68-2180452-30	LENS OPTIC / CLEAR / LOW
A/R	A/R	A/R	A/R	A/R	A/R	A/R	A/R	A/R	4	68-2180452-40	LENS OPTIC / GREEN / LOW
A/R	A/R	A/R	A/R	A/R	A/R	A/R	A/R	A/R	5	68-2180452-50	LENS OPTIC / RED / LO
1	1	1	1	1	1	1	1	1	6	38-0443007-00	O RING / 4.724 ID X .079 THK 70 DUROMETER BLK
2	2	2	2	2	2	2	2	2	7	15-065419-080	SCREW / #6 X 1/2 PPH PLASTIC-LOC
1	1	1	1	1	1	1	1	1	8	10-0323283-13	LABEL / MODEL L21E
3	3	3	3	3	3	3	3	3	9	15-101416-100	SCREW / 10 X 5/8 PPHSMS 410 SS
-	-	-	-	-	-	-	-	1	10	01-02860192-1	SUB ASSY BALLAST / L21E 12V CAST
-	-	-	-	-	-	-	-	1	11	01-02860192-2	SUB ASSY BALLAST / L21E 24V CAST
-	-	-	-	-	-	1	-	-	12	01-02860193-1	SUB ASSY BALLAST / L21E 12V PLASTIC
-	-	-	-	1	-	-	-	-	13	01-02860193-2	SUB ASSY BALLAST / L21E 24V PLASTIC
-	-	-	1	-	-	-	-	-	14	01-02860192-3	SUB ASSY BALLAST / L21E 12V CAST / PHOTOCELL
-	-	1	-	-	-	-	-	-	15	01-02860192-4	SUB ASSY BALLAST / L21E 24V CAST / PHOTOCELL
-	1	-	-	-	-	-	-	-	16	01-02860193-3	SUB ASSY BALLAST / L21E 12V PLASTIC / PHOTOCELL
1	-	-	-	-	-	-	-	-	17	01-02860193-4	SUB ASSY BALLAST / L21E 24V PLASTIC / PHOTOCELL
-	-	2	2	-	-	2	2	2	18	13-062C40-16J	SCREW / GROMMET #6 #8 FASTEX
1	1	1	1	1	1	1	1	1	19	38-0241596-00	SEAL / BASE MODEL 2000 SERIES B
1	1	1	1	1	1	1	1	1	20	10-0323189-00	LABEL / NASCAR BAR LOGO
1	1	1	1	1	1	1	1	1	21	10-0543882-___	LABEL / M-N P-N S-N / not shown

QTY	QTY	QTY	QTY	ITEM	PART NUMBER	DESCRIPTION
		*			01-0686357-1	L21E LED BEACON 12V PLASTIC / MAG MT.
		*			01-0686357-3-1	L21E LED BEACON 12V PLASTIC / MAG MT. / PHOTO.
	*				01-0686357-4	L21E LED BEACON 12V PLASTIC / VAC MT.
	*				01-0686357-3-4	L21E LED BEACON 12V PLASTIC / VAC MT. / PHOTO.
A/R	A/R	A/R	A/R	1	68-2180452-10	LENS OPTIC / LOW AMBER
A/R	A/R	A/R	A/R	2	68-2180452-20	LENS OPTIC / LOW BLUE
A/R	A/R	A/R	A/R	3	68-2180452-30	LENS OPTIC / LOW CLEAR
A/R	A/R	A/R	A/R	4	68-2180452-40	LENS OPTIC / LOW GREEN
A/R	A/R	A/R	A/R	5	68-2180452-50	LENS OPTIC / LOW RED
1	1	1	1	6	38-0443007-00	O RING / 4.724 ID X .079 THK 70 DUROMETER BLK
2	2	2	2	7	15-065419-080	SCREW / #6 X 1/2 PPH PLASTIC-LOC
1	1	1	1	8	10-0323283-13	LABEL / MODEL L21E
-	1	-	1	9	01-02860191-1	SUB ASSY BALLAST / L21E 12V PLASTIC / CIGAR PLUG
1	-	1	-	10	01-02860191-3	S. ASSY BLST. / L21E 12V PLSTC / CIG. PLUG / PHOTO.
1	1	1	1	11	10-0543882-___	LABEL / M-N P-N S-N
-	-	1	1	12	66-0421273-00	TAPE / MOUNTING / 90LB MAGNET
-	-	1	1	13	65-0010192-00	MAGNET / X-80
-	-	1	1	14	38-0143340-00	PAD / MOUNTING / MAGNETIC MOUNT
1	1	-	-	15	07-764648-023	PLATE / ADAPTER MAG-SUCTION CUP
2	2	-	-	16	15-081416-080	SCREW / 8 X 1/2 PPHSMS
1	1	-	-	17	08-1583927-05	SUCTION CUP / MAGNET MOUNT
1	1	-	-	18	16-1302820-06	WASHER / FLAT 1/4" 7/8 OD SS
1	1	-	-	19	14-130216-120	SCREW / 1/4-20 X 3/4 PPHMS SS

Magnet or Vacuum Mount
PART NUMBER KEY:
01-0686357

- HOUSING/MOUNT**
1 = PLASTIC MAG. MT
4 = PLASTIC VAC. MT
- COLOR: LO DOME / LED:**
A = AMB/WHT
B = BLU/BLU
G = GRN/GRN
R = RED/RED
1 = CLR/PC AMB
2 = CLR/BLU
3 = CLR/WHT
4 = CLR/GRN
5 = CLR/RED
- VOLTAGE**
- = 12 volt
3 = 12 volt (Photocell)

