

TECHNOLOGY AND APPLICATION

# TUNGSTEN HALOGEN LOW VOLTAGE LAMPS PHOTO OPTICS

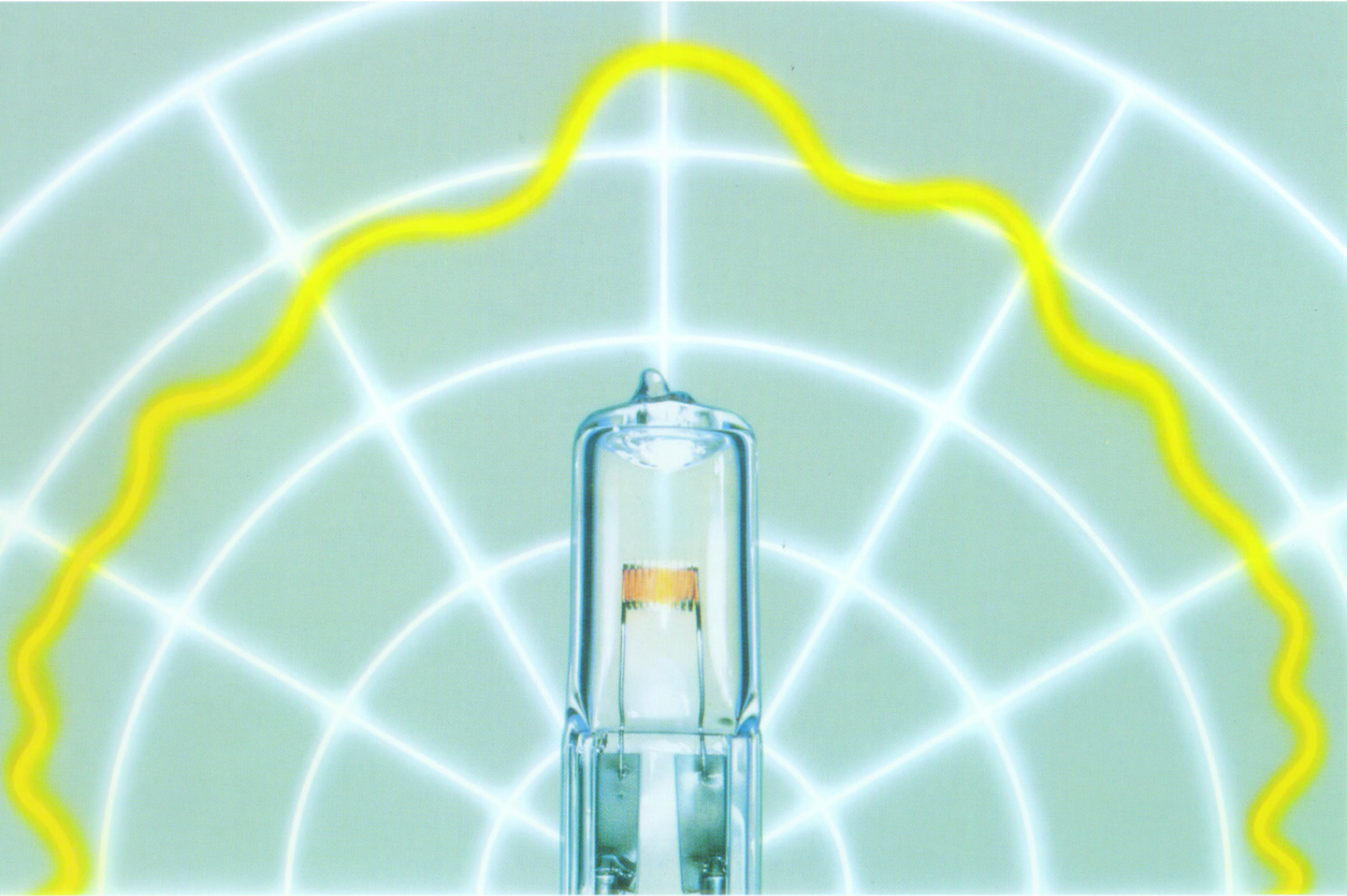

THERE IS LIGHT. AND THERE IS OSRAM.

**OSRAM**

**Lamp physics**

Generation of light by thermal radiation	4	Tungsten-halogen cycle	6
Radiation balance	4	Advantages of tungsten-halogen lamps	7
Tungsten temperature and color temperature	5	XENOPHOT®-lamps	7

**Construction of tungsten-halogen LV lamps**

Lamp bulb	8	Base designation	14
Filament	9	Reflector lamps	16
Coil geometry	9	Geometry	16
Coil design	11	Material	17
Sealing techniques	12	Coating	18
Lamp base	13	Dimensions	19

**Photometric characteristics**

General	20	Color temperature	24
Lamp laws	21	Color rendering index	25
Luminous efficacy	22	Dimming	26
Brilliance	22	Switch-off behavior	27
Spectrum	23		

**Electrical characteristics**

General	28	Rated current operation	30
Startup behavior	28	Series operation	31
Operating duty cycle	30	Battery operation	31
Fuse protection	30	Phase-shift control	31
Rated voltage operation	30		

**Lamp life**

Definition	32	Changes in the photometric and electrical data	34
Determinating parameters	32		
End of life	33		

**Handling and operation**

Handling	35	stability of materials	
Burning position	35	Optical filters	37
Cooling	36	Auxiliary reflectors	38
Clearance	37	Choice of lamp and misuse	39
Lampholder	37	Operation in a vacuum, weightlessness	
Thermal and geometrical	37		

**Safety and standards**

Safety	39	Fuse table	41
Standards	40	Base table	42
Standard lamps	41		

**Index**

# Introduction

The international standard IEC 357 determines three categories of lamps according to their design supply voltage: < 50 volts, 50–170 volts and > 170–250 volts. It is the first group, less than 50 volts, that is the subject of this brochure and which we refer to as „low voltage lamps“.

Tungsten halogen low voltage lamps are used today in many applications. Originally developed for photography, they have now won a place in traffic and signaling systems and in general indoor and outdoor lighting. However, they are still most widely used for performing special tasks in photography, films, TV, medicine, analysis, air traffic safety, science and technology. Over the past few years there has been a veritable explosion in the range of types available, with new versions continually being developed to satisfy an extremely wide variety of requirements.

This brochure is written for everyone using tungsten halogen low-voltage (or “LV”) lamps, and above all for equipment designers who want to make optimum use of the advantages that tungsten-halogen lamps offer.

The brochure concentrates on tungsten halogen LV lamps developed for applications other than traffic and signaling systems and general lighting – although of course most of the remarks apply to those fields too. Their suitability for mains voltage tungsten-halogen lamps is however strictly limited, and there are some major differences as regards standards and safety.



1 Tungsten halogen LV lamps of different wattages, in hard glass and quartz glass, single and double-ended, with round-core and flat-core filaments, with and without reflectors.

# Lamp physics

## Generation of light by thermal radiation

### General

Tungsten-halogen incandescent lamps – just like conventional incandescent lamps – are thermal radiators. This means that the light is generated by heating a solid body to a high temperature. The higher its temperature, the “brighter” it shines. In electric incandescent lamps the required temperature is produced by passing a current through an electrical conductor of greater or lesser conductivity. The incandescent material must fulfil two requirements in order to reach as high a temperature as possible and be capable of maintaining this over a long period of time:

1. High melting point
2. Low rate of vaporization

### Carbon filament

Early electric lamps used carbon as the material for the incandescent filament. At over 3500°C its melting point is high enough, but as it vaporizes relatively quickly the temperature cannot be taken to much over 2500°C for a lamp that will work in practice. The result is that the light is yellowish and the efficacy at about 7 lumens/watt is low. Today, carbon filament lamps are only used for decorative purposes.

### Tungsten

Carbon filaments were replaced as the light emitter in electric lamps by tungsten filaments as soon as the problems involved in manufacturing and still more in processing them had been overcome. The problem lay in the brittleness of pure tungsten which made it difficult to form into very fine wires. Today, the properties of tungsten metal can be controlled within wide limits by doping, in other words by adding tiny amounts of other materials.

Although with its melting point of 3383°C tungsten is not as good a thermal radiator as carbon, its low rate of vaporization even at temperatures approaching its melting point more than make up for this (see Fig. 2). Today, all electric incandescent lamps are manufactured with tungsten wires and filaments, and no incandescent material with better properties has yet been found despite intensive research.

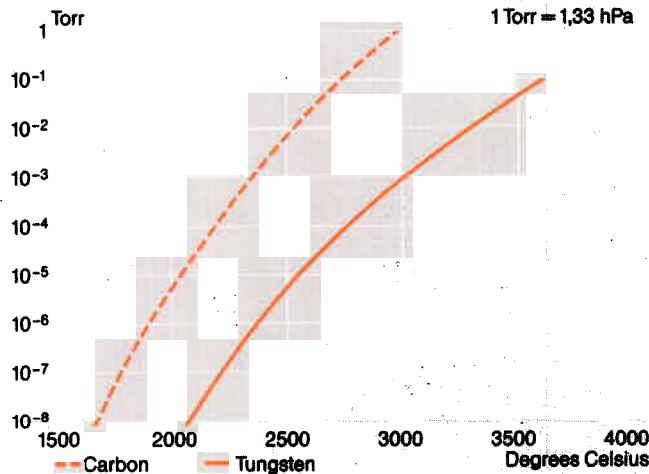

2 Vapor pressure curves for carbon and tungsten. Under like conditions the rate of vaporization is proportional to the vapor pressure. Source: D'Ans-Lax

## Radiation balance

By far the greater part of the electrical power consumed by the incandescent wire is output as electromagnetic radiation. The total radiation increases as the fourth power of the material temperature. The spectral distribution of the radiation, i.e. its distribution over the ultraviolet, visible and infrared (heat) ranges, shifts to shorter wavelengths in a kind of bell-shaped curve as the temperature increases. The peak moves out of the infrared towards the visible region (see Fig. 3). Unfortunately the melting point of tungsten does not permit the peak to be shifted into the visible region of the spectrum.

At the highest practicable temperatures, this peak is at about 850 nm (nanometers). The visible region ends at 780 nm. In this case about 20% of the total radiation is given off as “light”, about 0.3% in the UV region, and the rest (the majority) as heat.

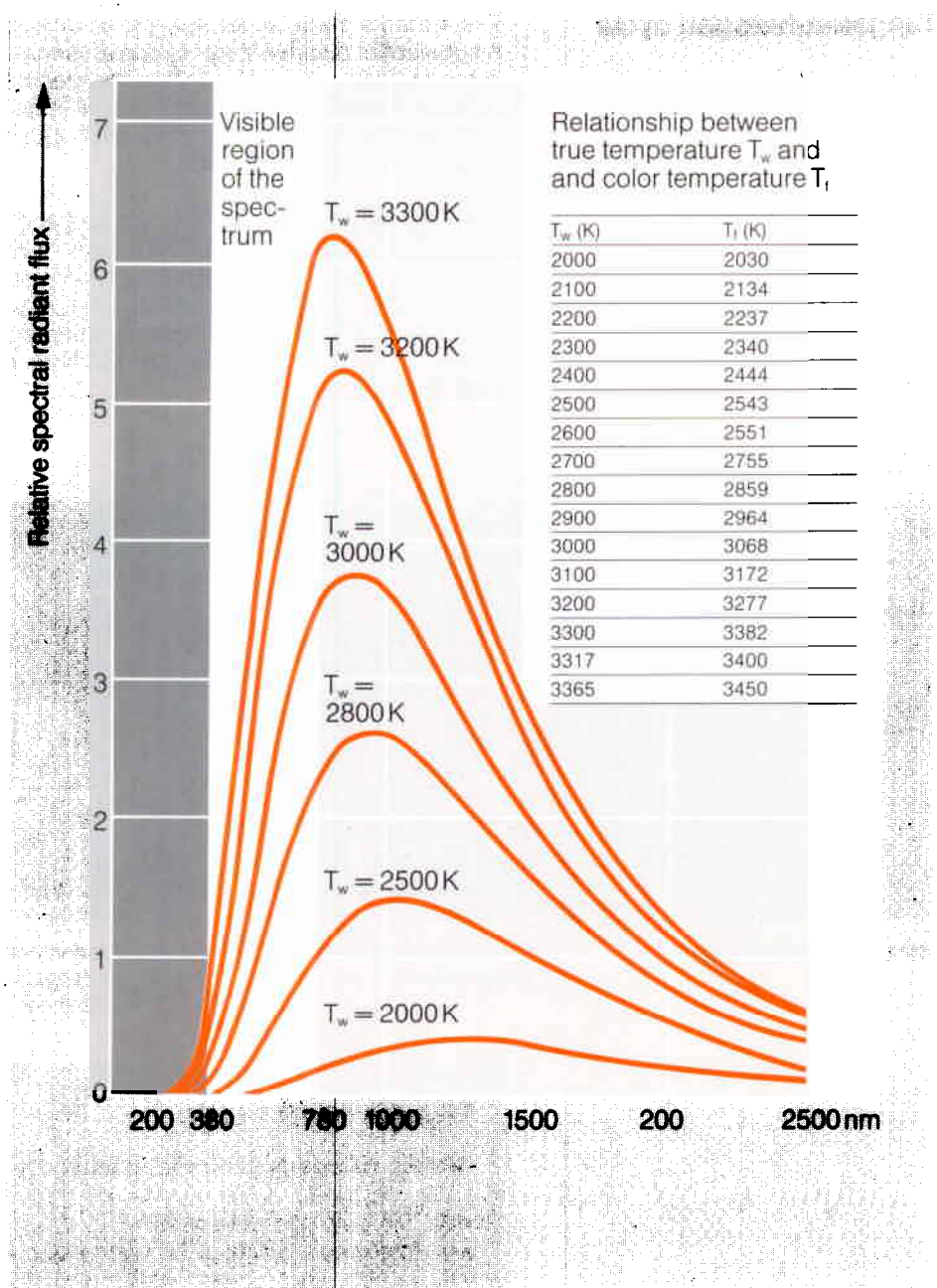

3 Relative spectral radiant flux for tungsten filaments at different true temperatures. Table comparing "true temperature" with "color temperature".

### Tungsten temperature and color temperature

For an ideal "black body" (in the physical sense) the color temperature is equal to the true temperature. The color temperature is measured in Kelvin (K), the true temperature more practically in Celsius ( $^{\circ}\text{C}$ ). The two only differ by 273.15: Kelvin = Celsius plus 273.15. The higher the color temperature, the whiter the light; the lower the color temperature, the more yellowish and reddish the light.

Tungsten, however, is not a "black body"; its emissivity is less, i.e. the total radiation emitted is less than in the ideal case. One could say that tungsten is a gray body radiator. But even that would only be a half-truth, because in the short-wave region tungsten is a better emitter – though still not as good as the ideal black body – than in the long-wave (red) region. This variation of the emission coefficient has a positive effect on the radiation characteristics of tungsten in that its color temperature is higher than its equivalent true body temperature. In the region of interest for lamp technology around 3000 K, this amounts to 60 – 80 K (see also the table in Fig. 3).

An upper limit for the color temperature is given by the melting point of tungsten and the requirement for minimum lamp life and the operating duty cycle (see section on "Electrical characteristics", page 30); it lies at about 3550 K.

## Tungsten-halogen cycle

The remarks made so far apply to all incandescent lamps, with or without halogen. A substantial disadvantage of conventional incandescent lamps without halogen is the reduction of luminous flux and decrease in brightness during the life of the lamp. The vaporized filament material is deposited on the inner wall of the glass bulb and blackens it in the process. Some of the light generated is absorbed there before it can leave the lamp.

The tungsten-halogen cycle – devised and tested forty years ago and used in lamp technology for about thirty years – provides the remedy. If the lamp bulb is filled with an inert gas (usually krypton or xenon) mixed with traces of a halogen element (usually bromine or iodine), the tungsten atoms and molecules vaporized from the incandescent wire can be intercepted before they reach the wall of the bulb, and returned to the filament, with the result that the glass bulb stays clean (see Fig. 4).

4 Schematic drawing of the tungsten-halogen cycle in tungsten halogen LV lamps

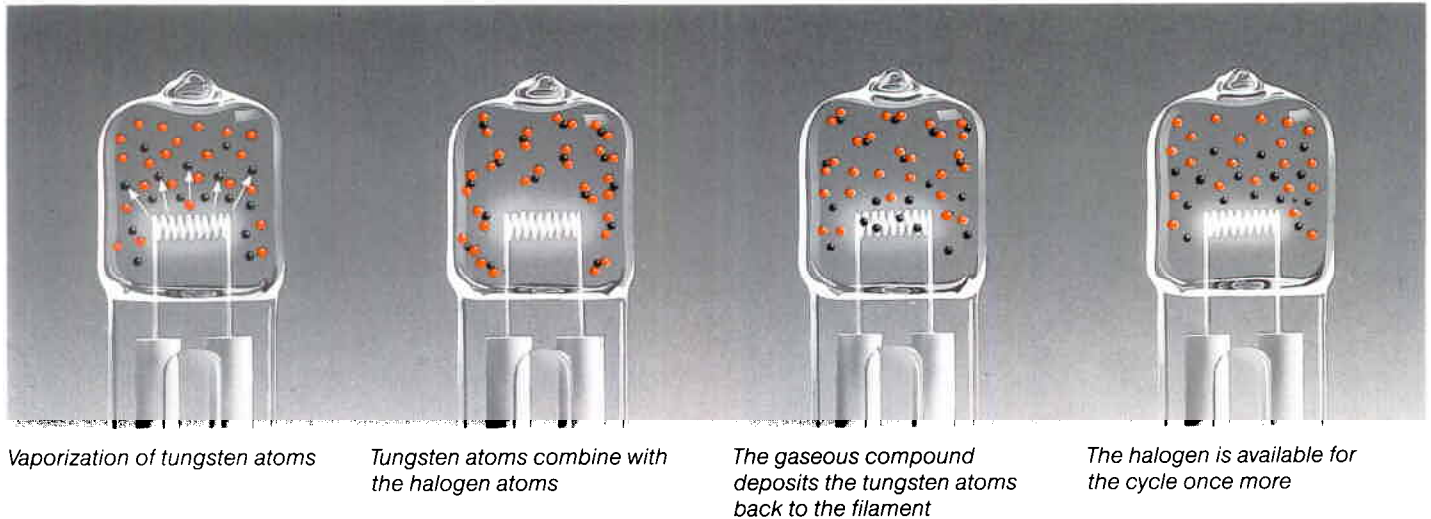

### Tungsten-halogen cycle

#### Adding halogens prevents blackening of the bulb

- ➔ The bulb can be smaller
- ➔ Expensive quartz glass can be used
- ➔ Its high strength permits a higher internal pressure
- ➔ The vaporization of tungsten is slowed down
- ➔ The filament temperature can be increased
- ➔ The luminous efficacy is higher

5 Using the tungsten-halogen cycle to suppress bulb blackening effect gives brighter lamps

Unfortunately the vaporized atoms are not returned to their original places, but are deposited elsewhere. Otherwise in theory there would be an “eternal incandescent lamp”.

Though simple in principle, the tungsten-halogen cycle is an extremely sensitive chemical system which depends on a large number of parameters. An important variable for example is the wall temperature of the bulb, one of the factors responsible for returning the vaporization products to the filament.

The fact that they remain equally bright to the end of their life is not the only advantage of tungsten-halogen lamps. They also convert electric current to light more efficiently.

This works as follows:

- In conventional incandescent lamps the vaporized tungsten is deposited on the glass bulb. To keep the light loss as low as possible, the bulb surface is large so that the absorbing layer is thin and widely distributed. As the bulb does not blacken in tungsten-halogen lamps, it can be very small.

- Because the bulb is very small, more expensive glass can be used; normally quartz glass.
- Because quartz glass is very strong and the bulb is small, the gas pressure in the lamp can be increased.
- The higher gas pressure suppresses the vaporization of the incandescent filament to a greater extent.
- As the lamp has a small volume, economic considerations also allow the use of a more expensive fill gas such as krypton or xenon, which suppresses the vaporization of the incandescent filament to a greater extent than the usual lamp gas (nitrogen and argon).
- A reduced rate of vaporization of the incandescent filament can either be used to increase the lamp life, or if the lamp life is unchanged the filament temperature can be increased.
- A higher tungsten temperature not only means a higher color temperature ("whiter" light), but also greater efficacy in terms of lumens/watt.

## **Advantages of tungsten-halogen lamps**

### **Tungsten-halogen lamps**

- are small
- do not blacken
- have greater efficacy
- have a higher color temperature

## **XENOPHOT®-lamps**

OSRAM introduced its "XENOPHOT®" tungsten halogen LV lamps some years ago for special applications in photography, film, airport lighting and so on. This technology is based on the principle that the vaporization of the tungsten can be influenced not only by the pressure of the gas enclosed in the lamp bulb but also by the choice of gas. Tungsten-halogen lamps are usually filled with krypton. This is obtained from the air, in which it occurs at a concentration of about 0.0001%. The rate of vaporization can be greatly reduced by using xenon as the fill gas. The reason is that xenon atoms are larger than krypton atoms. Xenon too is obtained from the air but as it is much more rare (concentration only 0.00001%) it is correspondingly more expensive to extract.

### **XENOPHOT®-technology for higher-quality lamps**

#### **Filler gas: xenon in place of krypton**

- Higher atomic mass
- Better suppression of tungsten vaporization
- Higher filament temperature
- Increased luminous efficacy (up to about 10%)

The reduced rate of vaporization of the tungsten can either be used to increase lamp life or – if the life remains the same – to increase the luminous efficacy and the color temperature by raising the temperature of the tungsten. In both cases, using the standard krypton lamp as the starting point, the filament dimensions have to be recalculated and the lamp filling modified.

Luminous efficacy can be increased by about 5-10% with the "xenon effect", which corresponds to a color temperature increase of about 100 K. XENOPHOT® technology can only be used for low-voltage lamps. In high-voltage lamps the lower ionizing energy of xenon would lead to electrical discharge in the lamp bulb. See also the section on "Lamp life", page 32.

# Construction of tungsten halogen LV lamps

## Lamp bulb

### Material

Tungsten-halogen lamps cannot be manufactured using the same glass as conventional incandescent lamps. Firstly, the tungsten-halogen cycle requires high bulb temperatures which would cause undesired vaporization of the enclosed gases out of the "soft" glass; and secondly, to achieve an effective reduction in the vaporization rate of the tungsten, fill gas pressures have to be used at which normal glass would break.

The standard material for tungsten-halogen lamps is therefore quartz glass, which can easily allow bulb temperatures of up to 900°C (its softening point is far above 1000°C) and operating pressures of up to 20 bar. In special cases (see also the section on "Sealing techniques", page 12, special hard glass with a softening point considerably above that of normal lamp glass can be used, especially for lamps in the low-wattage range up to about 50 watts. This may have advantages for the photometric design characteristics or for the cost of manufacture.

### Shape

Quartz glass for tungsten-halogen lamps is supplied to the manufacturer in the form of cylindrical tubes.

The geometry of the starting material can still be more or less recognized in the shape of the finished lamp bulb, especially of course in double-ended lamps. In most types of single-ended lamp the cylindrical shape is deformed to varying degrees by the pinch with its lead-in wires at the bottom and the exhaust tube at the top. The lower the wattage, the smaller the lamp and the greater the deviation from a cylindrical bulb shape.

Generally speaking, the optical quality of quartz glass bulbs is considerably lower than that of the blown bulbs used in conventional incandescent lamps. This is partly due to the fact that quartz glass with its higher melting point is more difficult to process, and partly it is the price that must be paid for a cost-effective manufacturing process.

### Exhaust tube tip-off

All incandescent lamps must have the oxygen removed from their atmosphere. In tungsten-halogen lamps the fill gas must additionally be brought to a considerable pressure before the lamp body is hermetically sealed.

The first incandescent lamps had an exhaust point or "belly button" in the bulb top by which they were connected to the pump during manufacture. Later, this exhaust tube tip-off was hidden in the lamp base.

In tungsten-halogen lamps, for which a completely new manufacturing process had to be invented because they had to be filled to positive pressure, the exhaust tube tip-off is clearly visible on the bulb. In double-ended lamps it is usually in the middle of the tube, in single-ended lamps opposite the pinch.

This means that this "blemish" often lies in the middle of the path of the light beam. Depending on the layout of the filament and of the optical system in which the lamp is used, this may cause scattered light reflections. Where these are unacceptable, the bulb top can be frosted. This is normally done by sand blasting, with no impairment of bulb strength if the sand blasting is done properly. So far there are very few lamps on the market without a visible exhaust tube tip-off. These are evacuated, cleaned and filled through the pinch, a technically very demanding manufacturing process in which the quality of large-scale production quantities must be closely monitored.

### Pinch

The leads are hermetically sealed into the quartz glass or hard glass bulbs by pinching.

The prefabricated internal lamp structure is inserted into the bulb, the bottom end of the tube heated to well over 1000°C or even 2200°C depending on whether it is made of hard glass or quartz glass, using natural gas or, if necessary because of the higher temperature, oxyhydrogen flames, and then pinched flat with hard alloy jaws. The outer surface of the pinch is suitably shaped to give it maximum mechanical strength, for example, or to enable a base to be fitted later.

## Filament

### Material

The material used for the incandescent wire (also known as the incandescent filament, or filament for short) is always tungsten.

To fabricate a wire suitable for lamps from the pure metal requires a complex doping and heat treatment process. This process gives the wire the ductility needed for processing and ensures that it does not distort over extended periods of operation in a lamp. It goes without saying that rigorous cleaning is necessary before the lamp is finally sealed to prevent harmful gases being given off by the metal during the life of the lamp.

### Wire dimensions

The electrical data of a lamp, and also its photometric data which to some extent is a function of the electrical data, is determined by the dimensions of the wire.

The wire length is mainly determined by the lamp operating voltage. The higher this is, the longer the piece of wire the lamp bulb must contain. The wire in a 24 volt lamp is between 10 and 14 cm long, the wire in a 12 volt lamp only half that length.

The wire diameter is mainly determined by the required lamp wattage and life. The higher the wattage, the thicker the wire, and hence also the stronger it is mechanically.

In practice, the wire data is also affected by the shape of the filament, the way it is suspended in the lamp bulb, and the fill gas. All the variables and parameters are linked together by a complicated multidimensional system of equations, and no parameter can be selected on its own.

## Coil geometry

### Filament geometry

A thin, straight wire has extremely poor emission characteristics and is difficult to fit into a small lamp body, quite apart from the fact that this geometry has little to recommend it in most applications, particularly those discussed here.

The long wire is therefore wound into the shape of a coil, or better a long spring. This can effectively increase the efficacy of the lamp – the individual turns heat each other up, producing a higher wire temperature for the same wattage input – and also enables the light emission characteristics to be matched to the requirements of special applications within wide limits.

The different types of coil most commonly used today and the resulting filament geometries are dealt with in the following sections. Because of its outstanding importance for the photometric properties of lamps, filament shape is one of the major characteristic features of a lamp type.

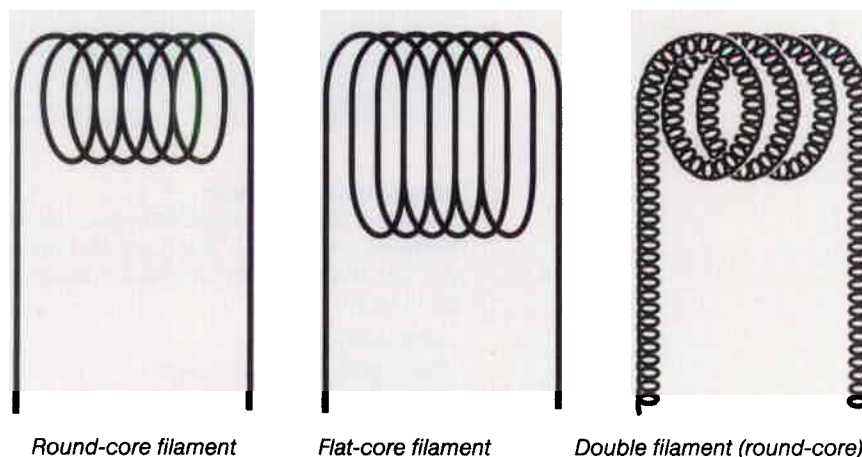

6 Different filament configurations in common use

### Filament orientation

An axis can be defined for every lamp. This is called the lamp axis. It is generally determined by the more or less cylindrical lamp body and usually passes symmetrically through the base.

The filament, for whose main dimension an axis can also be defined, can take up one of two orientations with respect to this axis (see Fig. 7):

– lamp axis and filament axis parallel: **axial filament**

– lamp axis and filament axis perpendicular to each other: **transverse filament**

The filament orientation is always axial in double-ended cylindrical lamps.

In single-ended lamps, there are about the same number of types with axial and transverse filaments. It is usually the application that determines the filament orientation, and occasionally factors relating to manufacture. The majority of hard glass lamps have transverse filaments because of their other design characteristics.

In lamps with axial filaments, a requirement disliked by lamp manufacturers occasionally occurs: lamp axis and filament axis do not coincide, the filament axis being offset from the lamp axis.

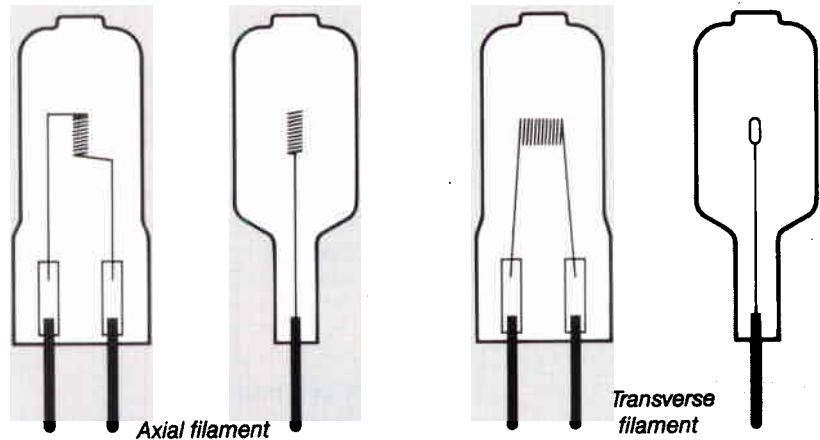

7 Tungsten halogen LV lamps with axial and transverse filaments

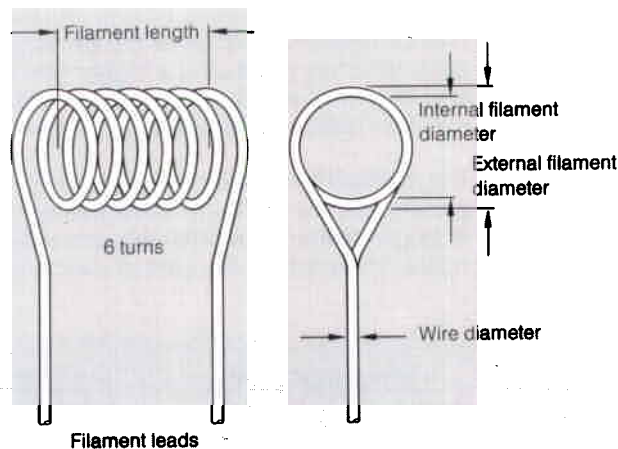

8 Parameters of a round-core filament

### Round-core filaments

The basic filament shape on which all others are based is the **round-core filament** (see Fig. 6). Turns are laid spirally one next to another on a cylindrical rod. The resulting filament structure is described by the following parameters (see Fig. 8):

- Filament length
- Internal filament diameter
- External filament diameter
- Number of turns
- Filament pitch in turns per mm shaft length
- Filament leads

As regards the emission characteristics, very little light is emitted along the cylinder axis, as only the last turn is visible and contributes to the luminous intensity generated. The radiation is approximately isotropic about the cylinder. Depending on whether the filament is oriented transversely or axially in the lamp bulb, this emission characteristic is influenced by the bulb shape, the base and the exhaust tube tip-off.

### **Flat-core filament**

If the cylindrical shape of a round-core filament is pinched across its axis, a flat-core filament is produced (see Fig. 6). It is fabricated by winding the tungsten wire round a rectangular rod.

Instead of diameter and length, a flat-core filament is specified by the length and width of the flat side of the filament and the thickness of the rectangular shape. The light emission characteristics are markedly different from those of a round-core filament. Maximum light is only radiated perpendicularly to the large filament surfaces, so to speak to the front and rear. The luminous intensity emitted from the end faces and narrow edges is minimal. This filament configuration is advantageous mainly in non-axially-symmetrical light collection systems, a typical example being the condenser system in a slide projector beam path. A special type of flat-core filament is the square filament, in which the light-emitting surface is square. This is mainly used in microscope lighting.

### **Double filament**

Where lamp voltages are greater than 24 V, the wire is usually too long to be fitted into a compact filament field. In this case it is advisable to wind the long length of wire into a double coil (see Fig. 6): the tungsten wire is first wound into a very fine primary coil, and this is then wound once more round a second, thicker core. The primary coil can only be seen by very close observation. The secondary coil usually takes the form of a round-core filament. This technique learned from high-voltage lamp engineering can be used to fit a large amount of wire into a very small space.

## **Coil design**

### **Covered filament**

As was mentioned in the section on "Lamp physics" (page 4) tungsten is not an ideal black body radiator. In special cases, the surface area can be enlarged to increase the emitting power of a tungsten filament. This is done by spinning a second, much thinner tungsten wire round the actual filament wire. The greater surface area of tungsten obtained in this way can emit up to 20% more radiation. The effect is only short-lived however; recrystallization in the tungsten wire while the lamp is operating causes the covering wire to be incorporated gradually into the main wire. The surface of the filament becomes smooth once more after about 10 hours and the benefit is lost.

### **Modulated filament**

Maximum lamp efficacy is obtained by bringing the filament to a temperature as close as possible to the melting point of tungsten. To extract the maximum benefit, the temperature must be even throughout the length of the filament. Normally, however, this is not the case. The turns in the middle of the filament heat each other up, while at the ends this heating effect is lost on one side. This means that the ends of the filament are cooler than the middle. To counteract this, the filament can be manufactured with "modulated pitch" by winding it more closely together at the ends than in the middle. This necessitates an elaborate mechanical method of winding the filaments, and outstanding stability of the filament throughout the life of the lamp. Because of the high cost, this method is only worthwhile in special applications that demand the maximum obtainable efficacy of light generation in lumens per watt.

### **Segmented filament**

Just to complete the picture, we shall also take a look at "segmented filaments". These have virtually no part to play in low-voltage lamps because filament lengths are always relatively short. They are important in double-ended medium and high-voltage lamps, and represent the state-of-the-art in copier lamps. In the latter case, in which a single lamp has to illuminate the entire length of a DIN A4 page so that it appears **evenly lit** when viewed through the imaging optics, the filament is divided into luminous and non-luminous areas or segments. To achieve the required evenness, the luminous segments are closer together at the ends of the lamp than in the middle; allowance must be made for the "edge drop" of the optical system (cosine to the power of four law) and the lack of filament segments outside the format area.

### General

In order to make a filament incandescent by passing a current through it, the current must be conducted into the lamp bulb from outside. This is done with the lead-in wires which must be hermetically sealed into the lamp body. In this process, it is necessary to outflank the laws of physics. Apart from a few anomalies, all materials expand when heated, though by different amounts. Quartz glass for instance has a very low coefficient of expansion (= relative change in length per °C), hard glass a somewhat higher one, and metals the highest. If lead-in wires were to be sealed tight into quartz glass, they would rapidly expand when the lamp became hot and shatter the glass.

The two methods used in LV tungsten-halogen lamp technology to avoid this catastrophe are the subject of the next two sections.

### Hard glass

Hard glass has a considerably higher coefficient of expansion than quartz glass. Specially constructed wires or wire alloys can be directly sealed or pinched into the glass.

An essential characteristic of these wires is that their expansion behavior is similar to that of the types of glass used in lamp engineering. The construction of lamps using hard glass is extremely simple. The filament is welded to the wire ends inserted into the open lamp bulb. The lamp is pinched, and the ends of wire projecting to the outside can be connected directly to the current source.

Because of this construction, most hard glass low-voltage lamps have a transverse filament which can easily be attached between the two wire ends.

### Quartz glass

Compared with metals, the coefficient of expansion of quartz glass is virtually zero. Directly pinching the wire is therefore not feasible as it would break the glass or cause a leak.

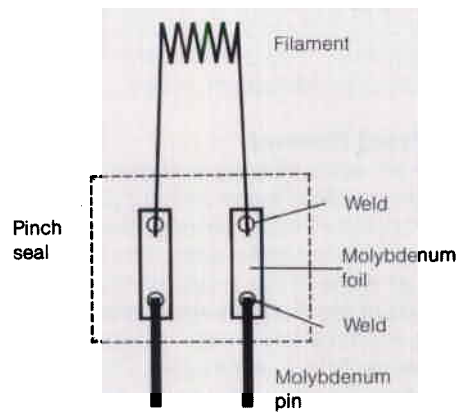

9 Elements of a molybdenum foil seal

In this case, a foil seal must be used (see Fig. 9). In place of a wire, a very thin foil is embedded in the quartz glass. The band is made of molybdenum (a metal similar to tungsten), is 2 to 4 mm wide depending on the lamp current, and 10 to 20 micrometers thick – half as thick as an average strand of hair. Its longitudinal edges are etched very sharp. As the band is pinched into the quartz glass and heated up it undergoes a minimal amount of expansion across its thickness, as this itself is very low, and the quartz glass is capable of absorbing the resulting forces. The expansion of the band across its width would be considerable in absolute terms, but here the knife-edges come to the rescue; their cutting angle is precisely calculated, and they “bury” themselves in the quartz glass without breaking it. The overall design of the system comprising lead-in wires and filament can be complicated. The tungsten filament is welded to short molybdenum wires, the molybdenum wires in turn to the molybdenum foils, and lastly molybdenum wires are welded to the ends of the molybdenum foils to act as the outer electrical contacts. Only for simple single-coil lamps the filament ends can directly be welded to the foils (see fig. 9).

## Lamp base

### Definition

The base or bases of a lamp serve primarily to connect it electrically and secondly to mount it. The base should not be confused with its counterpart, the lampholder (or socket), which is always part of the equipment in which the lamp is fitted. In order to restrict the flood of new base designs as much as possible and to ensure that lamps from different vendors can be interchanged, the most important base data – above all the geometry – is defined in national and international standards. The section on "Safety and standards" (page 42) contains a table and illustrations of the bases currently available for tungsten halogen LV lamps.

### Double-ended

Double-ended tubular tungsten-halogen lamps are fitted with the same base at both ends. The most common base is the R7s base, a small ceramic shaped part with a small nickel plate inserted to make the contact. In the lampholder, spring-mounted contact pins press against these metal plates.

Cable bases occasionally occur in the low-voltage range; in these, a cable is welded to the molybdenum pins; the welding area is more or less elegantly concealed.

### Single-ended

Most tungsten halogen LV lamps have a single-ended base. Either the molybdenum pins projecting from the pinch are used directly to make the connection, in which case the base is called a glass base, or the pins are connected to some kind of base. The most important types are described below.

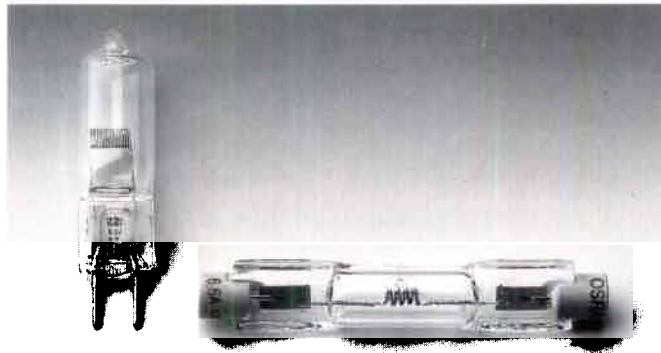

10 Examples of single and double-ended lamp bases

### Glass base

This is the simplest base design. The lamp is contacted and mounted directly at the molybdenum pins. The distance between the pins is standardized, typical values being 4 and 6.35 mm. (Hence the designation G4 and G6.35. "G" for glass.) Common pin diameters are 0.7 and 1 mm. In long-life and special lamps, the pins can be platinum or gold plated or encased to permit corrosion-free contacting over a long period of time.

### Ceramic base

This is a more convenient version of the glass base. The pinch is cemented into a ceramic trough, the Mo pins suitably connected to the contact pins in the base. The ceramic part enables the lamp to be handled and fixed in the lampholder more easily. The thickness of the pins can be selected to suit the lamp's current rating. The two pins can be of different diameters in order to define the mounting position. In tungsten halogen LV lamps the most usual pin spacings are 6.35 and 9.5 mm. Because of the good dimensional stability of ceramic materials, this type of base can also be used for prefocus lamps (see top of page 14).

### Metal base

The most popular use for metal-encased bases is for tungsten-halogen lamps in traffic and signaling systems. The contact is made either with the metal case and a central ground contact, or with two isolated ground contacts next to each other. Tungsten halogen LV lamps for special applications mainly use the prefocus type of metal base. See next section.

### Prefocus base

Lamps with prefocus bases – such as single-ended lamps for airport lighting – are individually aligned with respect to the base during manufacture. The reference level is frequently given by an adjustment ring. The alignment is to the (energized) filament. Where lamps have very narrow tolerances for high-precision applications it is pointless to check the alignment when the lamp is cold, as the expansion of the lamp's internal structure can result in deviations that may well lie in the tenths of a millimeter range.

Prefocus bases are sometimes fitted with flexible cables for electrical connection.

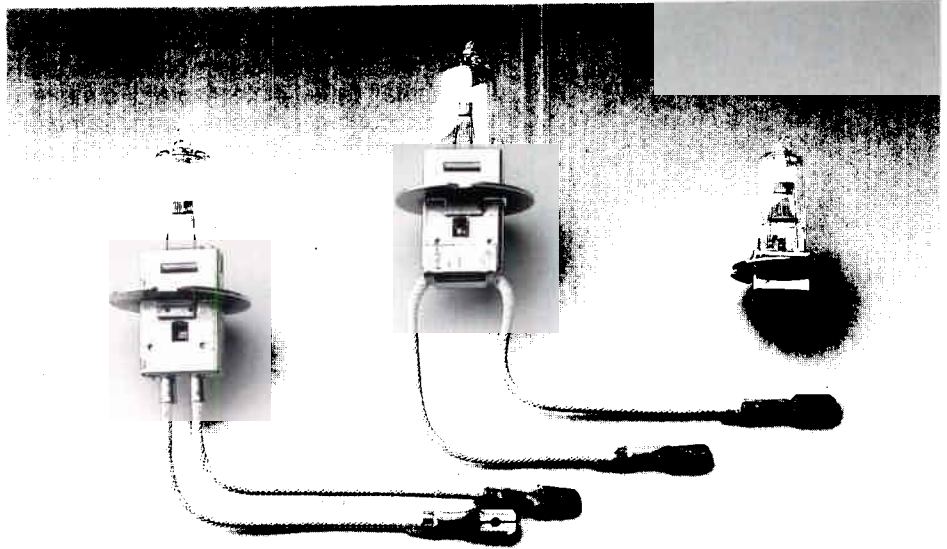

11 Examples of prefocus bases

### Cement-free base

Bases are normally bonded to the glass lamp body with cement. This special base cement has high resistance to moisture and thermal stress.

Nevertheless, wherever mechanical stress in the form of vibrations is combined with large temperature changes in a damp atmosphere there is the possibility of the cement in long-life lamps becoming brittle. A cement-free connection between lamp and metal base has been invented for these applications, a prominent example among special lamps being the proven PK 30 d base for airport lighting systems.

## Base designation

A system of abbreviations has been devised for bases and their associated lamp-holders. This system has now won widespread international acceptance and is included in the relevant standards.

The abbreviations are a combination of letters and numbers, the meanings of which are explained below. Special attention should be paid to the bases most commonly used for tungsten halogen LV lamps as listed in the "Safety and standards" section (page 42).

Detailed explanations are given in the relevant standard which is listed in the same section.

A complete lamp base designation takes the following general form:

**A B C - D / E x F**

The lampholder designation is a subset of this:

**A B C - D**

This provides a simple identification for lamp bases and their associated lamp-holders.

Only lamp bases are considered below. Often in practice, only part of the complete designation is used; details are omitted if there is no risk of confusion.

**Component [A]:**

This consists of one or more capital letters which define the type of base. The main ones are:

- G** Base with two or more projecting contacts such as pins or studs. G bases are also called pin-type bases. Important examples are G4 in the low-voltage range, and G22 in the high-voltage range. Originally derived from "glass base".
- P** Prefocus base or adjustable base for lamp-base-lampholder systems with close tolerances.
- K** Base with cable connection (K stands for German 'Kabel' = cable)
- R** Base with recessed contacts.
- B** Bayonet base.

If one letter is not sufficient to define the base, more than one may be used. A "PK" base would be a prefocus cable base. The most important feature is given first. If there are not enough features defined with a letter to distinguish between types of base, the letters X, Y, Z and U are used alone or in combination. An example is the G6.35 and the GY 6.35. These bases are alike except for the diameter of their contact pins: 1 mm and 1.25 mm. GX9.5: ceramic base with 2 like pins spaced 9.5 mm apart; GY9.5: ceramic base with 2 pins of different diameters spaced 9.5 mm apart.

**Component [B]:**

This is a number giving the approximate value of the most important base dimension in millimeters.

- G bases: the pin spacing
- P bases: the size of the adjustment ring
- K bases: the diameter of the base sleeve
- R bases: the diameter of the ceramic ring (not of the recessed contact plate; an important example is the R7s)

The following contact spacings are common for pin-type bases in the LV range: 4 mm / 5.3 mm / 6.35 mm / 9.5 mm.

**Component [C]:**

This is a lowercase letter giving the number of contacts or connections. The following codes are used:

- s One contact (single)
- d Two contacts (double)
- t Three contacts (triple)
- q Four contacts (quadruple)
- p five contacts (pent...)

Example: R7s; a base with a single recessed contact

**Component [D]:**

The core designation of the base (which is also used for the lampholder) is followed by a hyphen after which come additional distinguishing features. The latter are usually only named if there would otherwise be a risk of confusion.

Example: PG22-6.35; prefocus pin-type base with an adjustment plate diameter of 22 mm and a pin spacing of 6.35 mm.

**Components [E] and [F]:**

Component D may be followed by a slash, after which come additional dimensions linked by a lowercase "x" (multiplication sign). These describe secondary geometrical characteristics of the base, for example length (height) and diameter of covers or fixing edges.

## Reflector lamps

### Definition

Tungsten halogen LV lamps with integral reflectors – reflector lamps for short – are not strictly speaking lamps but lighting systems.

Their characteristics are determined by the "build-in lamps", by the reflector design, and also by the alignment of the lamp in the reflector. These are highly complex systems with a great deal of design freedom.

Because of the wide variety of designs on the market, this brochure can only give a brief summary of individual characteristic features.

### Build-in lamps

Single-ended tungsten halogen LV lamps are always used as build-in lamps. They are mounted in the axis of the reflector with the base pointing out from the reflector apex towards the rear.

The filament configuration is generally determined by the beam characteristic required for the system. All types are used, from transverse filaments through axial and flat-core filaments to double filaments.

An important point for system designers to note is that some build-in lamps project beyond the front edge of the reflector. This is to some extent defined in the standards.

### Base

The simplest method of making the electrical connection is to use the molybdenum pins projecting towards the rear. Sometimes these are fitted with covers or flat contacts, for instance where currents are high. Cable connections are also occasionally used to separate the electrical contact spatially from the heat source (the lamp).

The area round the base pins can be screened with ceramic covers and lids.

System designers must note the dimensions of the reflector neck which is usually present. See the section on "Safety and standards" (page 39) regarding this too.

Only occasionally is the electrical connection also used to mount the reflector. As reflector lamps usually form part of precisely aligned optical systems, to obtain optimum results the lamp manufacturer's fitting instructions and the standards must be exactly followed when installing lamps in systems.

Different methods of mounting the reflectors are used: a holder at the edge of the reflector, pressure on the back reflector closure, reflector edge centered in a cone, edge adjusted at an angular stop.

The designation of the bases of reflector lamps follows the rules described under "Base designation" in the section on "Bases", page 14.

## Geometry

### Size

The defining dimension of different reflectors is the external diameter of the reflector front opening.

Two basic sizes have become established. These have been designated "MR 16" and "MR 11" in English usage. "MR" doubtless originally stood for "metal reflector", though now this is forgotten and unimportant. The number is the reflector diameter in eighths of an inch (1 inch = 25.4mm). Thus the "MR 16" reflector has a diameter of about 50 mm, the "MR 11" one of 35 mm.

It is important to note that these are rough guidelines only, and there are fine differences particularly in the "MR 16" size. See section on "Standards", page 40.

### **Focusing**

Focusing reflectors concentrate the light generated by the build-in lamp on a more or less small spot at a defined distance from the reflector, and in its axis. The reflector geometry used for this is an ellipsoid. The lamp filament lies in the first focal point of the ellipsoid, and hence the focus is in the second.

It is important for equipment designers to remember that the mounting distance is the distance from the area of maximum light concentration measured from the front edge of the reflector. Depending on the optical system, its input aperture (such as film gate or light guide input) should be more or less precisely at this distance. It may be useful and necessary to deviate from this if there are special requirements such as even illumination.

### **Collimating**

Collimating reflectors generate parallel beams of light, as far as is technically possible with given lamp parameters and reflector sizes. The shape of the reflector must be a paraboloid. The smaller the filament dimensions of the build-in lamp and the larger the free aperture of the reflector, the smaller can be the resulting beam angle. A round-core axial filament ensures a rotationally symmetrical beam characteristic where required, which is only slightly disturbed by the longer filament lead.

Sometimes the build-in lamp is deliberately misaligned slightly in the reflector to obtain a larger beam angle.

### **Facetting**

Structured rather than smooth reflector surfaces are frequently used to modify the light distribution, for example to improve evenness, increase the beam angle, or smooth or break up the light-dark edge.

This structure may range from a fine, scarcely visible grain to clearly visible faceting, the effect being correspondingly less or more pronounced.

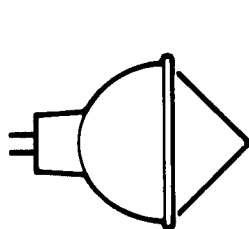

12 Focusing reflector

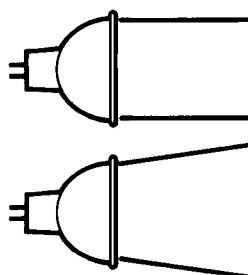

13 Collimating reflector

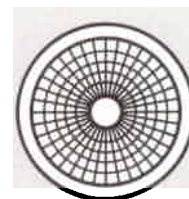

14 Facetted reflector

## **Material**

### **Metal reflector**

The simplest reflector material is metal, usually aluminum. Virtually any reflector geometry and structure can be produced quickly and cheaply by means of a simple deep drawing process. This advantage however contains within it one of its main disadvantages, namely that the geometric tolerances and dimensional stability are sometimes inadequate for exacting applications. Furthermore, the reflected radiation (we are talking here of cold light reflectors) can only be modified spectrally within very narrow limits. See page 18: "Types of coating".

### **Glass reflector**

Today's material of choice for LV tungsten-halogen reflector lamps is glass. The active inner domed reflector surface is suitably coated to obtain the required reflective properties. Nowadays such coatings are generally applied by vapor-deposition. The advantages of reflectors based on glass blanks are absolute dimensional stability, an outstandingly smooth active surface and, due to the fact that almost any type of coating can be used, the possibility of changing the spectral character of the reflected light.

Their disadvantage is that once a shape has been selected the only way to change it is very expensively by manufacturing new glass moulds.

## Coating

### Metal

A few types of lamp are still produced with metal-coated glass blanks (see Fig. 15). The coating is applied by vapor deposition and is normally of aluminum, which can in turn be given a protective coating of  $\text{SiO}_2$ , for example.

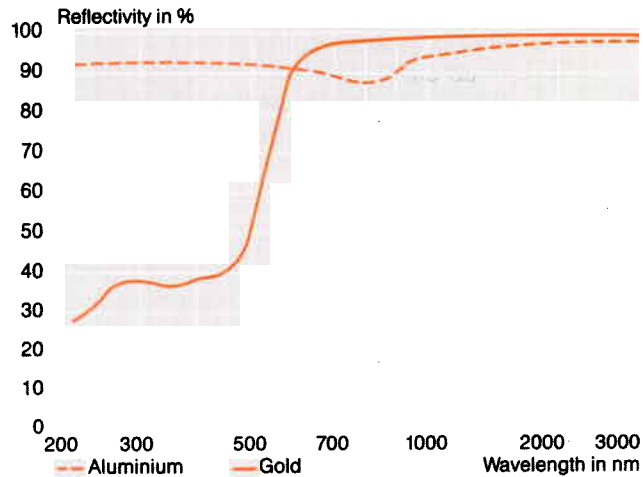

15 Reflectivity of aluminium and gold across the wavelength

Metal-coated reflector lamps are always the best choice if the entire spectrum of radiation emitted by the lamp is to be used. If it is mainly the infrared radiation which is of interest, a gold coating is vapor-deposited. The use of appropriately focusing reflectors enables high temperatures to be generated in a very small area, even through separating glass surfaces such as in vacuum equipment.

### Dichroic

Dichroic coatings produce their specific reflection properties through the phenomenon of interference. They consist of many (up to 40) very thin layers, each only a quarter of the wavelength of the light thick, alternately of materials with a high and a low refractive index. Fine tuning of the thickness of the layers and the way they are combined in packages enables virtually any reflection curve to be created. The maximum Reflectivity is nearly 100%, and there is virtually no absorption of radiation in the regions of low reflectivity. Dichroic reflectors are loss-free; what they do not reflect, they allow to pass through.

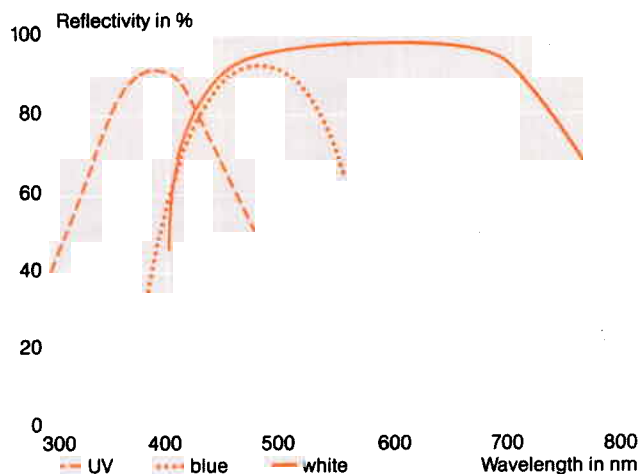

16 Schematic spectral Reflectivity of dichroic reflectors for "white" (cold light), "blue" and "UV".

The best known member of this group is the **cold-light reflector** (see Fig. 16). It reflects only the visible light between about 400 and 700 nm and allows the radiated heat to pass unhindered through the glass reflector to the rear. This means that the thermal load on the illuminated surface or object is much reduced. The **blue reflector** and the **UV reflector** are varieties of the cold-light reflector. In the first one only the blue region of the spectrum between 400 and 500 nm is reflected, in the second only the small amount of UV radiation emitted by the lamp. These find application in the field of chemical photopolymerization (UV-curing).

## Dimensions

### General

The main dimensions commonly used for specifying tungsten halogen LV lamps are listed below.

### Double-ended lamps

- Contact spacing: the shortest distance between the electrical contact plates
- Filament length: the length of the light-generating region (normally symmetrical)
- Bulb diameter: diameter of the quartz glass tube excluding the exhaust tube tip-off.

The dimension from the contact plate to the extreme other end of the lamp is also frequently given. This dimension is important for lampholder designers, because when a lamp is fitted first one contact is introduced obliquely from above into the sprung holder contact and pressed in, then the free end of the lamp is snapped into the other contact. The relevant dimensions are given in the standards.

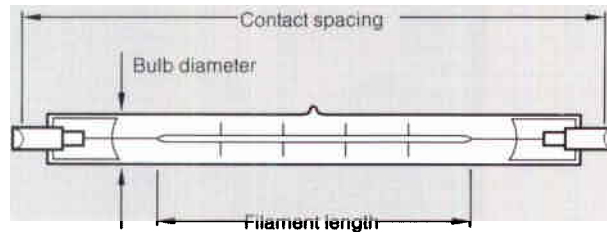

17 Specification of double-ended lamps

### Single-ended lamps

- Total length: overall length measured from the end of the base pin to the point of the exhaust tube
- LCL: light center length. Distance from center of filament to a defined reference plane in the base. This is often the end of the base pins, in prefocus bases the upper or lower surface of the adjustment plate.
- Bulb diameter: diameter of the glass bulb
- Width of pinch: this is usually greater than the bulb diameter
- Dimensions of the filament field: in flat-core filaments height times width in the filament axis; in round-core and double filaments diameter and length.

The tolerances and the position of the filament field are important.

A standard tolerance of  $\pm 1$  mm from the lamp's axis of symmetry is observed for the position of the filament field (or more precisely the center of the filament field). The axis of symmetry is frequently defined by the plane of the base pins and its center line. Closer tolerances are possible; these are associated with the base used, and increase the cost of manufacture.

The individual filament field tolerances are designed for the particular filament. It is important that they are measured when the filament is hot. They are different for a cold filament, and are unlikely to be of interest to anyone.

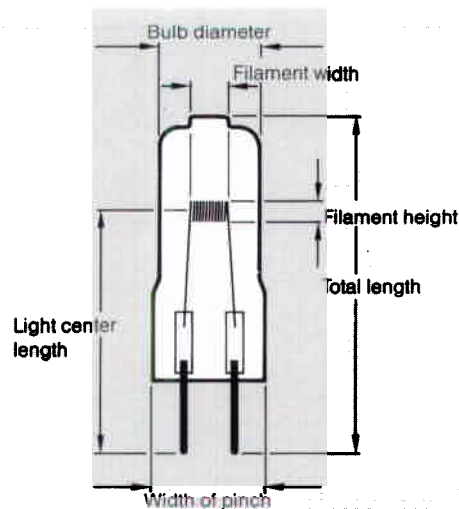

18 Specification of single-ended lamps

### Reflector lamps

- Total length: overall length from the front edge of the reflector to the ends of the base pins (if present). N.B.: the recessed lamp may project beyond the edge of the reflector.
- Reflector diameter: external diameter of the reflector with the tolerances specified in the standards. Not only the diameter has tolerances; the reflector can also be somewhat oval. This is important for designing an adjusting edge mount.
- Mounting distance: in focusing systems the distance from the front reflector edge to the area of smallest beam diameter. This dimension is not fully defined, especially for large mounting distances (over 100 mm with a 50 mm reflector opening) as the area of maximum light concentration is not sharply defined. See also sections on "Geometry"/"Focusing"/"Reflector lamps", page 17.

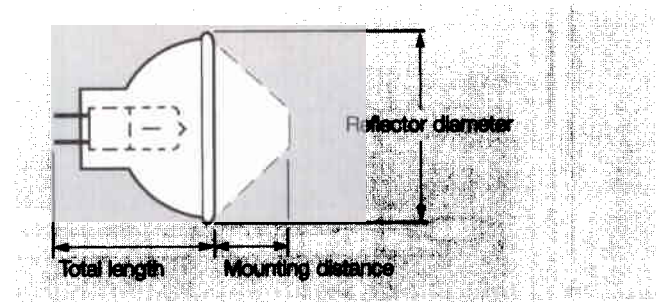

19 Specification of reflector lamps

## Photometric characteristics

### General

The most important feature of a lamp is that it emits light.

A number of terms, variables and units have been defined to objectively describe, name and measure "light". Two systems of units exist in parallel: the physical and the physiological. The first treats light as electromagnetic radiation with purely physical effects. Using this system the brightness of a light source would be specified in "watts", and connected in some way with units of length and angle. The physiological system takes into account the way the human eye evaluates the light source. As all eyes are different, a standard eye was defined internationally a long time ago. The characteristic of interest in this standard is the eye sensitivity curve or V-lambda curve (see Fig. 20). This states how "sensitive" the eye is to the different colors of light, or to put it another way it is a spectral sensitivity curve. Using physiological measurement, all the effects of light are evaluated taking this sensitivity distribution into account, and the "lumen" is used in place of the "watt".

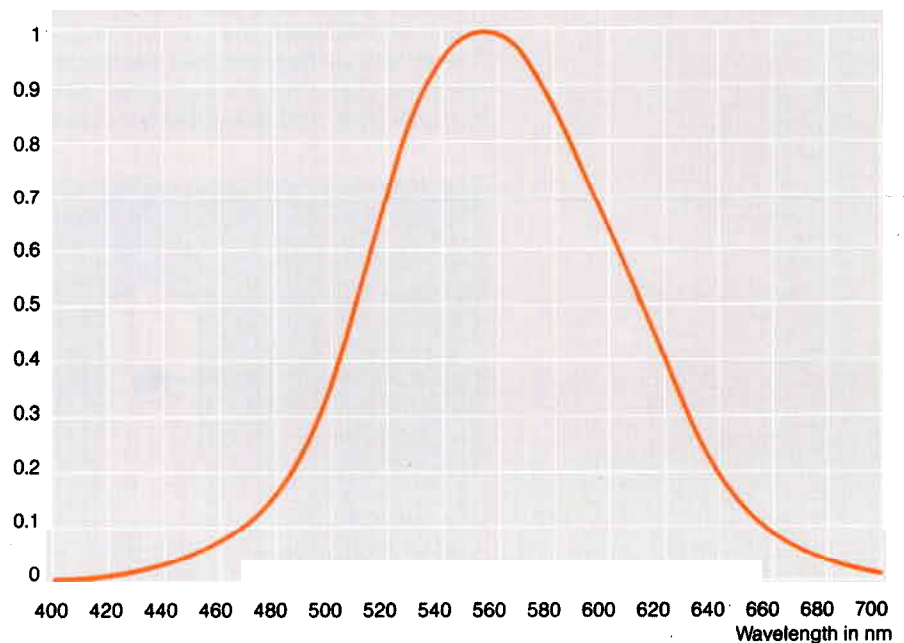

20 Eye sensitivity curve of the "standard eye".  
V-lambda curve according to DIN 5031 and IEC 1924

The physiological system is always adequate if the receiver of the light is the human eye, such as in slide projection, or a sensor developed to simulate the eye such as photographic film, or a television camera tube or chip. The system will inevitably fail if the light is intended for other effects, especially in chemical processes, or if radiation outside the visible region, in the UV and IR region, is to be included. In this case the physical system must be used. The following text mainly describes the physiological system of measuring light.

The most important terms used to evaluate electric lamps are:

- Luminous flux: the total light emitted is measured in "lumens", abbreviated to "lm".
- Luminous intensity: part of the luminous flux in one direction; luminous flux per solid angle; the unit is the "candela" abbreviated to "cd".
- Brilliance: portion of the luminous flux emitted in a specific direction by a surface element of the luminous body; the unit is "candelas per square meter or square centimeter", abbreviated to  $\text{cd}/\text{m}^2$  or  $\text{cd}/\text{cm}^2$ . This variable is important for rating the brightness impression of light sources and illuminated objects; what the eye sees is always the brilliance.

As well as these basic variables, the following are also important for rating lamps photometrically:

- Luminous efficacy in lumens per watt of electrical power consumed; the efficacy with which electrical power is converted to visible radiation.
- Color temperature in Kelvin (K) as a measure of how yellowish or bluish-white the light appears to the eye. This is closely linked with the temperature of the tungsten filament (see also sections on "Tungsten temperature and color temperature", "Lamp physics", page 5).
- Color rendering index CRI, which characterizes the color rendering quality of the light from a lamp. It is the same for all incandescent lamps by definition and equal to the maximum value of 100.

Further literature on this subject:

**IES Lighting Handbook Edition**

by the Illuminating Engineering Society of North America

**The Science of Color**

by the Committee on Colorimetry of the Optical Society of America

## Lamp laws

The following variables can be related in a fixed formula for incandescent lamps (see Fig. 21):

- Luminous flux
- Luminous efficacy
- Color temperature
- Electrical voltage
- Electrical current
- Electrical power consumption

In non-tungsten-halogen lamps, lamp life can also be added to this list as it is only determined by the physically measurable evaporation rate of the tungsten filament. In tungsten-halogen lamps, lamp life is also affected by the chemistry of the tungsten-halogen cycle. A fixed mathematical relationship with the above variables therefore only exists in a small, well-defined range (see section on "Lamp life" for further details, page 32).

The mutual dependence of these variables can be shown very clearly in a diagram if the deviation from the rated lamp voltage is used as the abscissa.

The following rule of thumb can be derived:

A 5% change in the voltage applied to the lamp results in

- halving or doubling the lamp life
- a 15% change in luminous flux
- an 8% change in power
- a 3% change in current
- a 2% change in color temperature

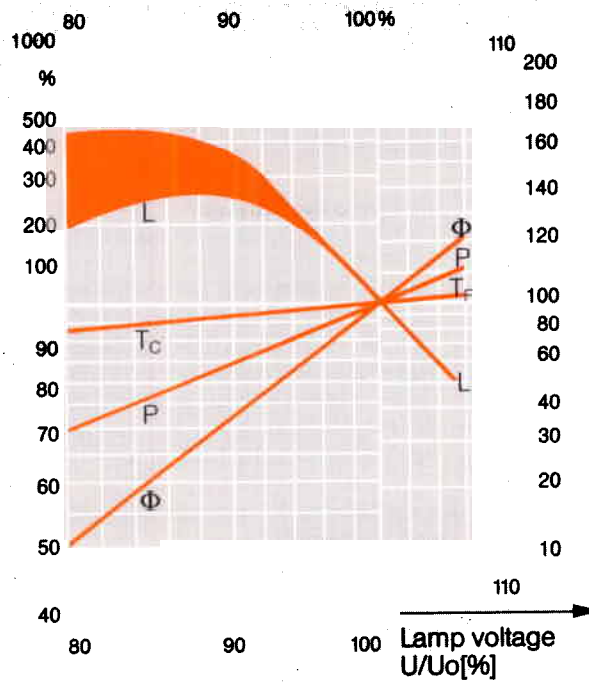

21 Tungsten-halogen lamp laws. Most important lamp data as a function of operating voltage

The limitation described above applies to lamp life. It must also be noted that increasing the voltage may in some circumstances not be permissible, depending on the design of the lamp; if it causes the tungsten filament to reach its melting point the lamp will burn out.

## Luminous efficacy

The luminous efficacy in lumens per watt states how efficiently the electric current is converted to visible light.

Early carbon filament incandescent lamps managed 3 lm/W, while the theoretical maximum is 683 lm/W – assuming that the electrical power input could be converted into a sharp spectral line where the eye sensitivity curve peaks at 555 nm (yellow-green). Actual incandescent lamps fall somewhere between the two, but closer to the lower end.

At the bottom of the range come household light bulbs at 14 lm/W, next are the high-voltage tungsten-halogen lamps at about 22 lm/W, going up to the maximum-load XENOPHOT® – tungsten halogen LV lamps (see section on “Lamp physics) at about 37 lm/W.

The higher the luminous efficacy, the shorter the life of the lamp because luminous efficacy can only be achieved by increasing the temperature of the filament. The melting point of tungsten forms the natural upper limit, and here the luminous efficacy would be 42 lm/W. However, because a lamp must also be capable of being handled mechanically and switched on electrically, the achievable limit is 37 lm/W.

## Brilliance

The brilliance of a light source determines how bright it appears to the eye or another imaging optical system.

The brilliance of the sun is 150,000 cd/cm<sup>2</sup> at midday in June.

In incandescent lamps, the brilliance depends on how hot the tungsten filament is – a direct relationship with lamp life can be seen from this –, and also on how tightly the filament has been coiled.

Maximum-load lamps with very small filament fields can achieve a brilliance of 3000 cd/cm<sup>2</sup>. Though this is far removed from the brilliance of the sun, it can give rise to glare, and it is therefore not advisable to look at an incandescent filament with the naked eye for long periods.

# Spectrum

As incandescent radiators, tungsten halogen LV lamps generate a continuous, gap-free spectrum of radiation ranging from the UV region through the visible and into the infrared region. See also section on "Lamp physics" (page 4). Compared with the daylight spectrum (see Fig. 22), the red portions of the spectrum always predominate in incandescent lamps. As the filament temperature increases, the maximum light emission shifts towards the shorter wavelengths. This means that up to the temperatures permitted for tungsten, as the filament temperature increases the proportion of visible radiation to total radiation becomes ever greater.

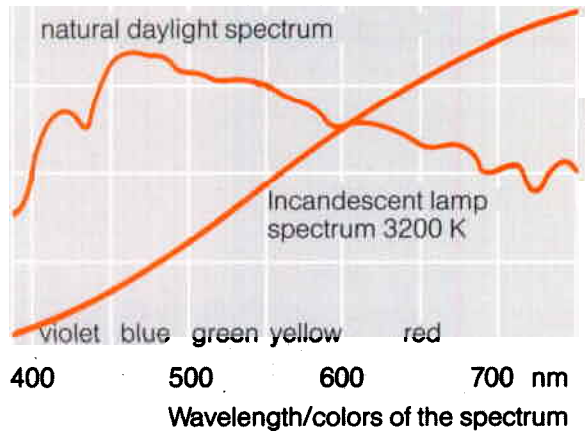

22 Spectral distribution of incandescent light and daylight (qualitative)

Fig. 23 shows this clearly by normalizing the distribution of radiation at color temperatures of 2800 K and 3300 K to the same luminous flux. Not only does the curve at 3300 K have a much smaller proportion of IR, but in the visible region the proportion of blue has considerably increased. This diagram could mislead us into assuming that for applications requiring the maximum possible IR radiation, a lower color temperature should be chosen.

As Fig. 3 in the section on "Lamp physics" shows, this is not the case. The total radiation output from an incandescent body rises as the fourth power of its temperature, while the shift of the maximum radiation is linear. This means that the higher the temperature, the greater the radiation output in **every** region of the spectrum.

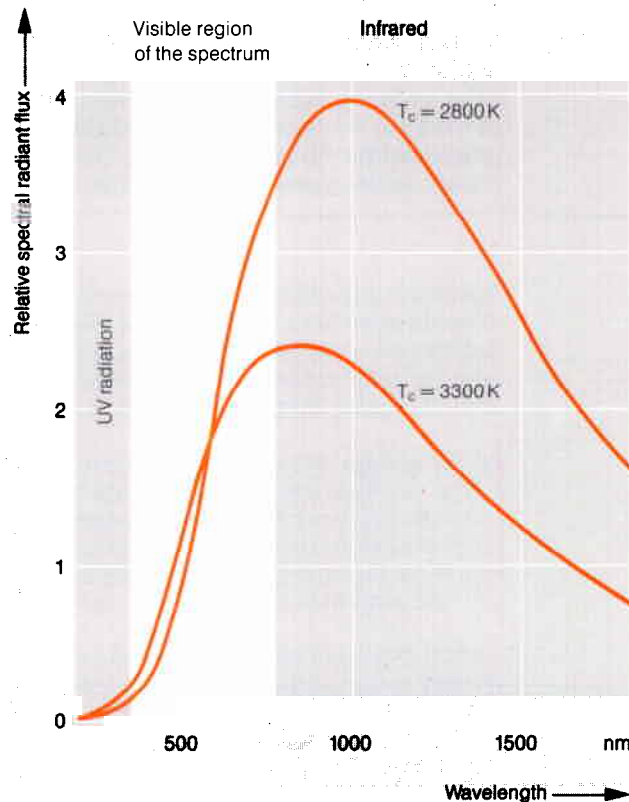

23 Relative spectral radiation distribution of lamps with different filament temperatures (and power consumption) standardized to the same total luminous flux.

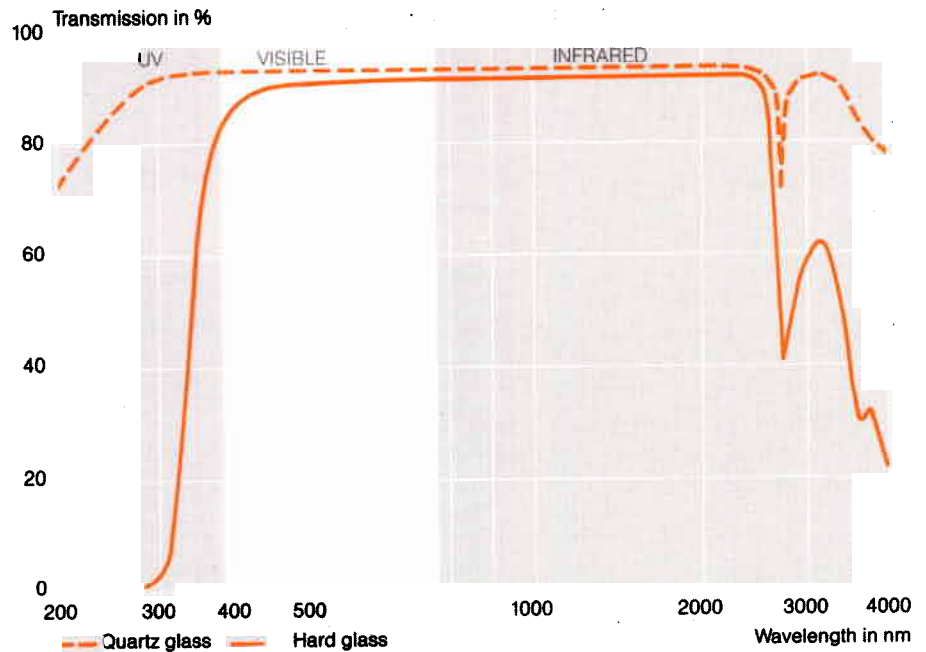

24 Transmission curves of quartz glass and hard glass (Corning 1724)

The spectrum is modified when the light passes through the lamp body due to the absorption that takes place there (see Fig. 24). In **quartz glass** lamps, the changes are almost below the threshold of perception. UV radiation is only absorbed in the region below 180 nm, and tungsten emits virtually no radiation in this region. In the IR region, quartz glass only has a small absorption point round about 2700 nm. In the visible region the transmission curve is smooth and horizontal.

The situation is quite different for **hard glass** bulbs. Below 315 nm, the border between UV-A and UV-B, hard glass lamps emit practically no UV radiation (less than 0.002% of the electrical wattage). There are also some dips in the spectrum in the infrared region. The absorption curve shown in Fig. 24 is only an example; considerable deviations from this are possible, especially in the IR region, because of the variety of possible hard glass compositions.

In case of reflector lamps, the total optical system must be taken into consideration for a meaningful specification of the spectral distribution. As in dichroic reflector layers the spectral reflectivity factor depends on the angle of incidence of the light, the measured spectral distribution also depends on which beams are processed by the optical system. Generally valid specifications of more than merely global character are therefore not possible.

## Color temperature

Spectrum and color temperature are closely and clearly related to each other in incandescent radiators. Since the influence of the bulb material on the spectral distribution of radiation in the visible region is negligible, as we saw previous section, the color temperature of lamps is also clearly correlated with the temperature of the tungsten filament (see section on "Lamp physics", page 4).

An advantage of tungsten-halogen lamps over conventional incandescent lamps is that, because the lamp bulb does not become blackened during its life, not only does the luminous flux remain constant but also the color temperature. Thin coatings of tungsten on the bulb absorb light in the blue region more than in the red, with the result that the color temperature of conventional lamps can sink by up to 200 K during their life.

As both the color temperature and the luminous efficacy (in lumens/watt) are directly connected to the filament temperature, there is also a direct relationship between the two variables. This does depend somewhat on the lamp design (in terms of wattage and voltage), but Fig. 25 can be used for high-load low-voltage lamps. This relationship is useful for estimating the color temperature of lamps for which no color temperature data is given in the catalog.

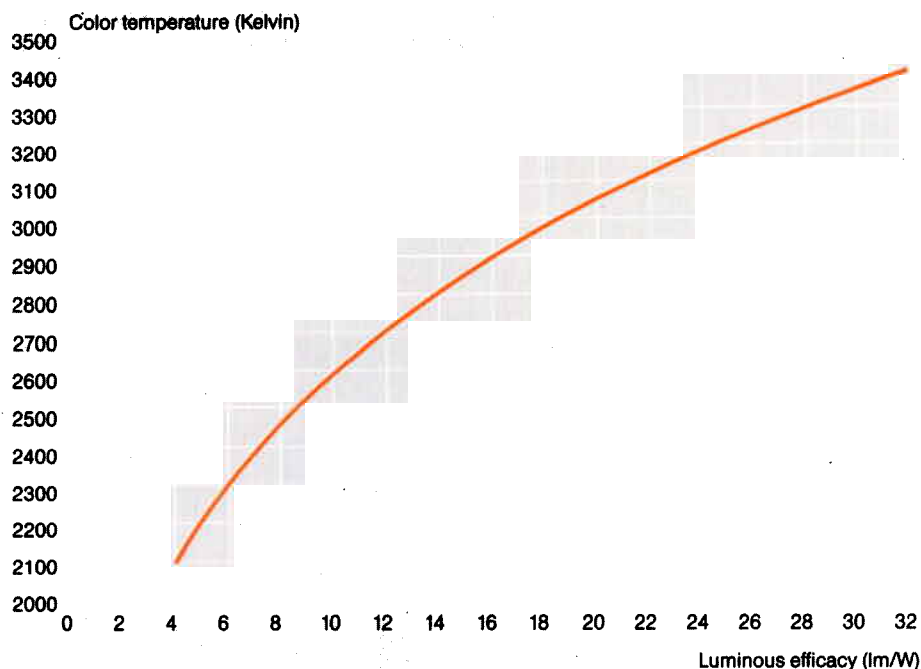

25 Relationship between luminous efficacy and color temperature for tungsten halogen LV lamps

In the region around 3000 K, the following easy-to-remember rule of threes applies:

**At 30 lm/W the color temperature is 3330 K.**

**With every 3 lm/W the color temperature changes by 100 K.**

The color temperature tolerance is mainly determined by the manufacturing tolerances for filament and wire, and so is directly linked to the lamp's electrical power consumption tolerance. Some types of lamp are designed for a fixed color temperature, for example lamps for video recording are designed for 3200 or 3400 K (professional and amateur). In these cases the color temperature tolerance is  $\pm 50$  K.

The remarks made in the section on "Spectrum" apply analogously to the color temperature of reflector lamps (page 23).

## Color rendering index

The general color rendering index CRI is used to describe the extent to which the color rendering properties of a light source (lamp) correspond to those of the light from a most similar "black body radiator". "Most similar" refers to the color temperature, which must be the same. This definition gives all tungsten incandescent lamps the maximum value of 100, regardless of their color temperature.

If the CRI of a (discharge) lamp is less than 100, this means that the light spectrum has gaps of greater or lesser size. When certain colors are illuminated, these do not shine at full intensity and may in extreme cases be left out or degenerate into a dirty gray.

The CRI is measured using the remission properties of specific well-defined colors. Normally eight different colors are used, sometimes more.

As the CRI of incandescent lamps is always 100 it is of relatively little interest for this type of lamp. And because tungsten halogen LV lamps do not blacken during their operating life, its value does not change over time. It can in fact only be influenced in reflector lamps if, as in the case of dichroitic cold-light reflectors, the reflectivity is not at the same level throughout the spectrum. Depending on the extent to which the lamp spectrum is cut, for example in the red region, the CRI may drop a few points. Reducing the CRI to 90 does in fact require very drastic interventions in the reflectivity.

## Dimming

When incandescent lamps are dimmed, they are operated at a wattage lower than their rated wattage. In **conventional incandescent lamps**, i.e. lamps without halogen, the response to dimming is immediate and direct: at the reduced temperature, the filament vaporizes less, which increases the life of the filament and reduces blackening of the lamp bulb. The lower color temperature and reduced efficacy may be disadvantageous. When heavily dimmed, a lamp will only consume electrical power and will not give out light, but only heat. In **halogen lamps** the relationships are less simple and clear-cut because of the chemical cycle. A certain minimum wall temperature is necessary for the vaporized tungsten to be returned from the inner bulb wall. The wall temperature depends on the power input to the lamp, and if this is reduced, the wall temperature drops too.

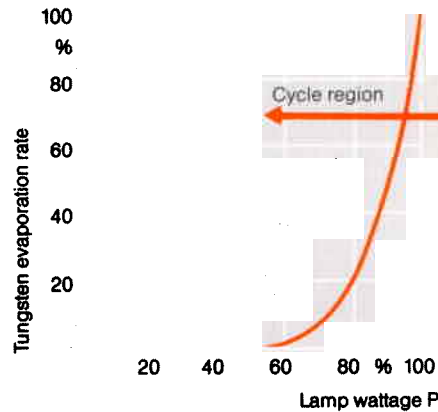

26 Dimming behavior of tungsten halogen LV lamps

In earlier tungsten-halogen lamps it was possible for the cycle to stop and the lamp to blacken when the wattage was considerably reduced ("heavily dimmed"). In modern halogen lamps on the other hand, ways have been found of conducting the cycle so that no blackening takes place at any level of dimming. As Fig. 26 shows, the cycle continues functioning down to filament temperatures so low that the evaporation rate of the tungsten filament is insignificant in terms of blackening. Modern halogen lamps – at least those for photo-optic applications – are dim-proof. This indicates that whatever the level of dimming used, the nominal lamp life is achieved (and only achieved, not exceeded sometimes to infinity as is the familiar pattern with conventional lamps). The quasi exponential dependence of lamp life on supply voltage – generally applicable to non tungsten-halogen lamps – is only valid for tungsten halogen LV lamps in the immediate vicinity of the rated voltage. "Immediate vicinity" should be interpreted as 5 to 10% (see also section on "Lamp laws", page 21). Further from the nominal area the chemistry of the lamp atmosphere intervenes in the process, in that the reduction of the rate of vaporization is countered by halogen corrosion at colder parts of the filament. This phenomenon causes filament material to be removed chemically in certain places irrespective of the temperature-dependent rate of vaporization. Lamp developers do however control the tungsten-halogen cycle in such a way that the nominal lamp life is always obtained, however dimming is carried out.

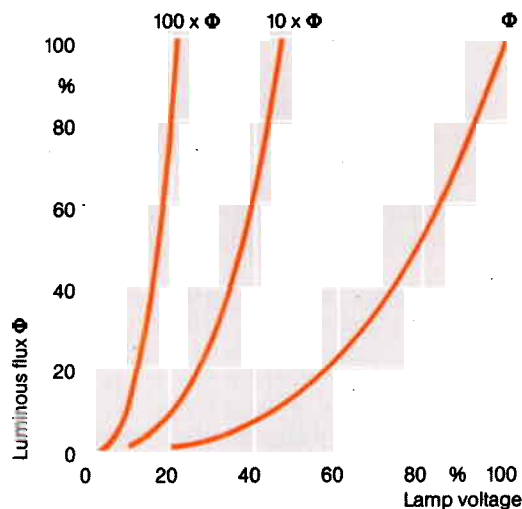

27 Luminous flux as a function of lamp voltage in the dimming of tungsten-halogen lamps

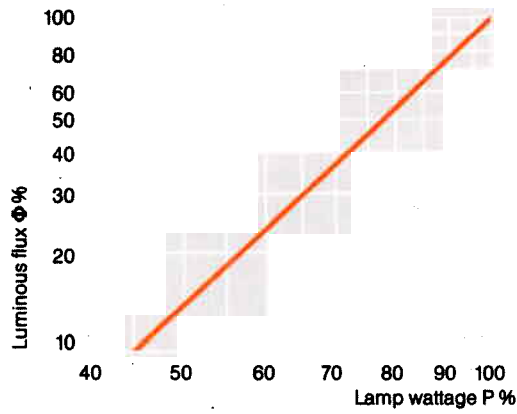

28 Luminous flux as a function of lamp wattage in the dimming of tungsten-halogen lamps

Lamps are generally dimmed in order to reduce their luminous flux. This is important for example in the lighting of airport runways, in order to adapt the brightness of the lamps to changing light conditions – from the brightest sunshine to the blackest night. Fig. 27 gives an overview of the relationship between luminous flux and lamp voltage; the example used here is a 100 W airport lamp, though the information can be applied, at least qualitatively, to all other LV halogen lamps. Fig. 28 shows the relationship between electrical power input and emitted luminous flux during dimming.

As the temperature of the filament changes when a lamp is dimmed, the color temperature of the light also changes. This must be taken into account if the application requires maximum constancy of color temperature, for example in photographic and video recording. Fig. 29 shows the quantitative relationships. The following rule of thumb applies:

**Half the luminous flux = Color temperature lower by 250K.**

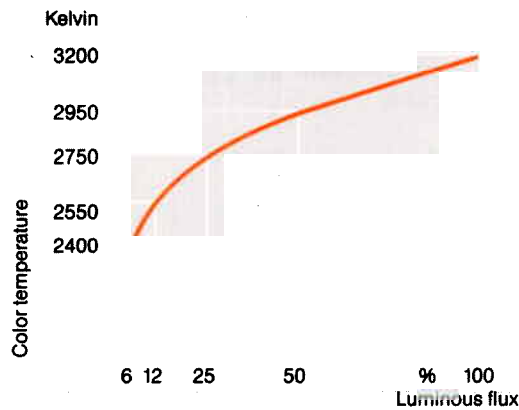

29 Relationship between lamp wattage and color temperature during dimming

## Switch-off behavior

If the current flowing through incandescent lamps is interrupted, the light dies away as the filament cools. In other words, lamps do not go out suddenly but show Switch-off behavior. The decay time – defined for the sake of convenience as the time until the luminous flux reduces to half its initial value – varies considerably from one type of lamp to another. It may vary from tens of milliseconds to tenths of a second. The main variable is the mass, i.e. thermal capacity, of the filament. The larger this is, the longer the afterglow. The filament mass in turn is approximately proportional to the lamp wattage and life and inversely proportional to its rated voltage. Hence long-life lamps with a low rated voltage and high wattage have the longest decay times.

# Electrical characteristics

## General

Tungsten halogen LV lamps are lamps for supply voltages lower than 50 V. The majority of types are designed for a set voltage, the so-called rated or nominal voltage. Only a minority are designed for operation with constant current, good examples being lamps for airfield lighting. As a rule, all lamp data – power consumption, luminous flux etc. – is measured at rated voltage. No tolerance is therefore specified for the rated voltage; it is the reference value.

The power input tolerances are defined by international standards. Until recently, IEC 357 (see also section on “Safety and Standard”, page 39) allowed a positive tolerance of 12% for tungsten halogen LV lamps for photo-optical applications. This tolerance is limited by contrast to 8% for new lamp designs, to match improved filament fabrication methods. As is usual in lamp standards, no lower limit is specified. It is implicit in the specification of **a minimum** luminous flux (for which, logically, no upper limit is given). In order to give users an optimum amount of light for the selected wattage, the medium wattages are usually considerably above the rated value. It is advisable to take this into consideration in the design of transformers or ballasts and in cooling.

Tungsten-halogen lamps can be operated with both direct and alternating current. As lamp life is for practical purposes determined only by the temperature of the filament, and this in turn by the average power input to the lamp (and not by the instantaneous power), there is no difference in respect of hours burned. Only in lamps with a life of 100,000 hours or more would differences in the type of current become apparent (there are no tungsten-halogen lamps with this life because it makes no sense). With direct current there is a slow transport of filament material which limits lamp life; with alternating current this is prevented by continuous polarity reversal.

Depending on the thermal capacity of the filament, if the lamp is operated at 50 Hz there the luminous flux is modulated (by 100 Hz). In very thin-wired tungsten halogen LV lamps the amplitude may be 5%. As the lamp wattage increases and the voltage and lamp life decrease, the modulation shift drops. In applications which are critical in respect of light modulation, such as scanning, either higher current frequencies or direct current must be used.

If a lamp's supply voltage (current) changes as a result of external influences such as mains voltage fluctuations cutting across a transformer, lamp behavior changes in accordance with the lamp laws (see above). Individual cases must be checked as to whether this can be tolerated or whether a stabilized power supply must be used.

## Startup behavior

When the filament is cold – before it is switched on – its resistance is up to 20 times lower than at operating temperature. Accordingly, at the moment when the supply voltage is applied to the lamp, a very high current flows, provided the power source is capable of supplying it. In practice a startup current 14 times greater than the steady-state current can be expected. As the filament warms up, its electrical resistance increases more or less simultaneously and the current drops. The peak current is reached within a few milliseconds and, depending on the type of lamp, is over in about 0.2 to 0.5 seconds. This does not mean however that the lamp has reached its steady state; the current stays above the equilibrium level for much longer than this as it is not only the filament that contributes to the total lamp resistance but also the lead-in wires, particularly inside the lamp.

With regard to these, there are marked differences in the behavior of hard glass and quartz glass lamps. As described in the section on “Construction of tungsten halogen low voltage lamps” (page 12) in quartz glass lamps the current is supplied via thin molybdenum foils, in hard glass lamps via solid wires.

The foil resistance can represent a considerable proportion of the total lamp resistance, which is normally not the case with sealed wires. In either case these additional resistances are temperature-dependent and do not reach their final value until the entire lamp body including the pinch has reached operating temperature. This may take up to several minutes but is normally about one minute.

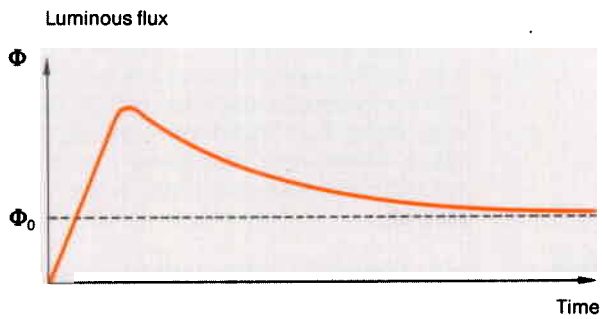
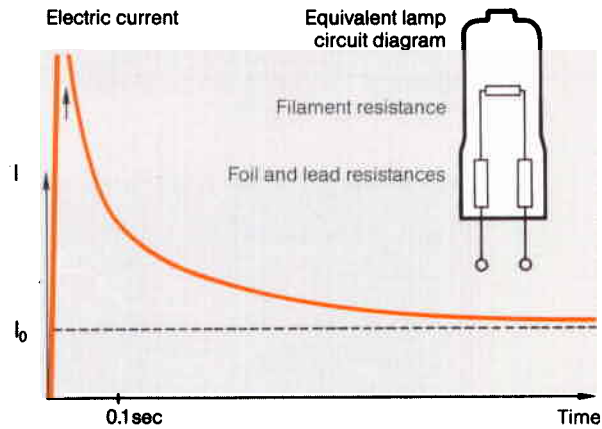

30 Schematic diagram showing the change with time of electric current and luminous flux in quartz glass lamps

The consequence for the luminous flux is that shortly after the lamp is switched on it rises from zero to a level initially above the steady-state value, and then approaches the latter asymptotically (see Fig. 30). During this start-up phase the filament is operated at "too high" a current level. This explains why the operating frequency has an effect on lamp life. Lamp designers in particular must allow for this, as the filament temperature must not be allowed to reach the melting point of tungsten during the inrush current phase. This also explains why the theoretically possible filament temperature and hence the theoretically possible luminous efficacy cannot be achieved in practice.

Where lamps must be switched on and off frequently due to their application, the negative effect of inrush current on lamp life can be avoided by operating the lamp with a current limiter. The term "soft-start" is often used for this type of operation, in which the current is brought relatively slowly and under control to its operating level without exceeding it.

Where lamps are operated intermittently, the "simmer mode" has also proved itself in practice. During the off periods a weak continuous current – about 10-20% of the rated current – is passed through the lamp, and this is enough to maintain thermal conditions in the lamp at a more or less constant level. Start-up then has no detrimental effect on lamp life even without an expensive current limiter.

## Operating duty cycle

A description has already been given of how every cold start has a negative effect on the life expectancy of a lamp due to the phenomenon of high inrush current (see previous section and “Electrical characteristics”, page 28). Added to this, the power source frequently produces a considerably higher voltage under no load than under load. To enable lamps to withstand this without shortening their life, they are designed for a start-up voltage of 108%. The circuit shown in Fig. 31 is used to check this parameter. Transformer T is the same as the one used to operate the lamp (for example 230 V/12 V). Using suitable equipment, the input voltage  $V_p$  is set so that the no-load voltage on the secondary side  $V_s$  – i.e. with no lamp connected – is 108% of the rated lamp voltage, or 12.96 V for a 12 V lamp. The circuit is then operated with a “typical” lamp – i.e. one known to be good – and the rated lamp voltage set with resistor R. The test lamps are then tested in this circuit without changing the settings, for a period of at least 3 seconds. This test procedure will shortly be included in IEC 357 (see section on “Standards”, page 40).

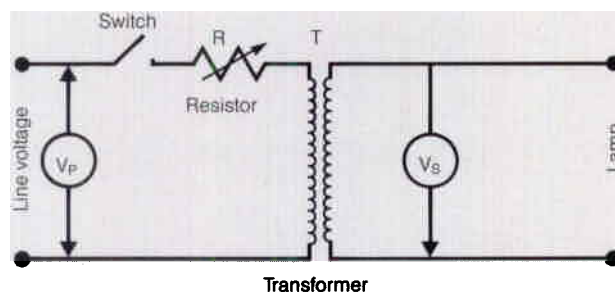

31 Circuit for checking the start-up voltage. See description above.

## Fuse protection

As described in detail in the section on “Lamp life” (page 34) when a lamp ends its life an internal short-circuit may occur. This causes an arc in the lamp which because of its negative current-voltage characteristic draws all the available current. Unless external fuses are used, there is a risk of the lamp exploding because of the momentary overload (which causes a rise in pressure). Lamps with a voltage rating of 24 V and more should therefore be protected with external fast-blow fuses. Where very high-current transformers are used the peak inrush current may sometimes cause problems; in such cases it must be reduced with suitable circuit design.

## Rated voltage operation

Most lamps are designed for a certain rated voltage, and adhere to the promised data such as luminous flux and lamp life if they are operated in **this** mode. As a result of the manufacturing process, the power consumption to individual lamps varies somewhat within each type of lamp. If “voltage lamps” are operated at constant current, those with a lower wattage (higher resistance) are operated at a higher output, with the consequence that the filament temperature is higher and the life shorter.

## Rated current operation

A few types of lamp are designed for constant-current operation, the main example being airfield lamps which are all operated in series with a 1:1 transformer between each. This is to ensure that all the lamps have the same brightness whatever the current setting. See Fig. 32 for a sample circuit.

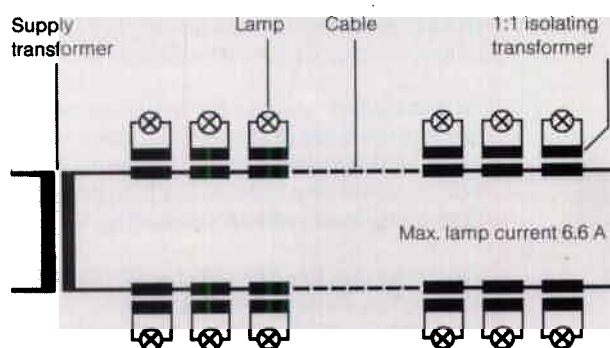

32 Schematic circuit diagram of current-controlled airport lamps connected in series

## Series operation

Operating several lamps in series is similar to constant-current operation. The current flowing through each lamp is not (or barely) determined by the individual lamp but by the total resistance of the group. This means that if “voltage lamps” are used, those lamps that would have a lower wattage in constant voltage conditions are operated at overload. The consequence is reduced life. Furthermore, if a filament burns out this may cause an arc to ignite in the lamp (see section on “Lamp life”, page 32). With the other lamps acting as current limiters it is possible that this one will burn steadily – until it explodes or the lamps are switched off. As searching for the failed lamp is a laborious business unless it has burst, replacement of the entire group is often the answer.

Connecting tungsten halogen LV lamps in series is not recommended. See previous section on “Constant current operation” for the exception to this.

## Battery operation

Portable equipment is often operated with batteries. Battery operation is a special form of direct current operation.

Two points must be noted in particular:

- Batteries usually have very low internal resistance. This means that in a cold lamp the inrush current can reach very high levels, placing a very heavy load on filament and lead-in wires, including the various welds connecting foils, wires and filament.
- When fully charged, the voltage of a battery is usually higher than its rated voltage. In high-load lamps – i.e. lamps with high luminous efficacy and the tungsten temperature nearly at melting point – the filament may burn out prematurely. The only remedy for this is to choose a less highly loaded lamp (i.e. one with a longer life), or a version specially optimized for battery operation by the lamp manufacturer, or special switching systems in the lamp circuit.

## Phase-shift control

If Tungsten halogen LV lamps are to be operated on line voltage, phase-shift control is a simple method of setting the power requirements of a lamp without using a transformer.

However, it is not advisable to use this method, at least in high-voltage networks (220/240 V), for the following reasons:

- The voltage difference is too great to achieve constant wattage in the lamp.
- The resulting current pulses are so narrow that the luminous flux can be noticeably modulated and the lamp flickers.
- A unfavourable phase angle can give rise to voltage differences between individual windings in the filament so great as to ignite a gas discharge which melts the filament.

# Lamp life

## Definition

The lamp life specified for tungsten halogen LV lamps is based on a defined **“average lamp life”**. This is the time after which, on statistical average, half of a not too small number of lamps fail. “Fail” means that the filament burns out. To be on the safe side, lamp manufacturers as a rule set the design value slightly above the promised “average lamp life”. This modifies the above definition to the time after which, on statistical average, half the lamps **may** fail. The lamp life distribution of individual lamps in a group approximately follows a Gaussian bell-shaped curve. Lamp manufacturers have the following to say about the width of this curve: individual lamp life is at least 70% of average lamp life. If for example the average lamp life is 100 hours, every lamp will last for at least 70 hours, except for premature failures – the black sheep of mass production which can never be entirely avoided. A mandatory percentage limit laid down internationally – the AQL – is specified for these premature failures (AQL stands for “Accepted Quality Level” and is part of a comprehensive statistical quality system in common use internationally, see DIN 40080). The AQL value varies for different groups of lamps (general lighting service, photo-optic applications, etc.). The tungsten halogen LV lamps under consideration here normally have an AQL of 6.5, which means in practical terms that 6.5% of the lamps in a sufficiently large random sample do not **have to** achieve the individual lamp life. In accordance with the lamp life definition, they may fail shortly after being switched on for the first time or, as in the above example, after 69 hours.

Normally, the life of a lamp ends when the filament burns out. Other causes of failure may occur if lamps are faulty or operated incorrectly, for example blackening or browning if the tungsten-halogen cycle malfunctions, recrystallization (clouding) of the quartz glass bulb, or deformation of the filament.

## Determinating parameters

### General

The life of a type of lamp is a feature “designed in” to the lamp. It can however be affected by a number of external parameters, usually adversely. The main possible influencing factors are described once more below. It is assumed that the lamps are operated correctly and in a way that rules out gross damage such as mechanical breakage or overheating. See also the section on “Handling and operation”, page 35.

### Overvoltage

This probably has the greatest effect on lamp life, particularly as regards the generally high-load lamps used in photo-optical applications. High-load means that in steady-state operation the filament is near to the melting point of tungsten. The amount by which lamp life is reduced in the event of overvoltage is governed by the lamp laws (see section on “Photometric characteristics”, page 21). There may be deviations from the theory if the life is already very short at rated voltage, for example 15 hours and less. In this case even a small voltage rise can bring the filament to its melting temperature during the startup phase (the time during which the peripheral resistances of lead-in wires and connections are low because of their low temperature). The lamp burns out. The response of the XENOPHOT® – series of lamps operating at the physical limit is especially critical.

### Dimming

The changes that occur in the photometric data when tungsten halogen LV lamps are dimmed are described in the section on “Photometric characteristics” (page 20) as is the fact that modern tungsten-halogen lamps are dimproof, i.e. they can be operated at any wattage between zero and the rated value without blackening. The exponential increase in lamp life predicted by the lamp laws can however only be expected between 5 and 10% below the rated value. Further from the rated value, the theoretical gain in lamp life is partly offset by chemical processes in the lamp’s atmosphere. Although generally there is a net gain, where lamp life is important users should only count on the rated lamp life. All the dimming mode parameters are involved here.

Simmering is a special form of dimming (see section on “Electrical characteristics”, page 29) Here, lamps operated intermittently are supplied with a low holding current in the intervals to minimize the inrush current surge.

In this context the question is frequently asked, to what extent can these intervals (and other periods of operation at reduced wattage) be offset against lamp life. Unfortunately, lamp manufacturers have no conclusive answer. The number of possible different operating modes – dimming level, dimming time, dimming cycle, type of lamp – is so great, and the response of various types of lamp so different, that it is impossible either to carry out suitable trials or to state generally applicable rules.

### **Switching frequency**

The “average lamp life” specification always refers to a “reasonably” long operating time. Reasonable means that the lamp and all its components must have reached operating temperature and the operating time should be at least as long as the startup time. Depending on lamp type (hard glass, quartz glass), lamp wattage and transformer, “reasonable” operating times amount to somewhere between a few minutes and a good quarter of an hour.

More frequent switching reduces lamp life, simply because the filament – provided the transformer allows – is subjected too often to the overload that occurs after switching on. See also the section on “Electrical characteristics: Startup behavior”, page 28. If the lamp is prevented from reaching operating temperature at all because it is operated in flashing mode, the bulb may even blacken. The start-up phase causes the tungsten to vaporize, but the bulb walls are too cold to allow the cycle to start and the vaporized material to be returned to the filament. If blackening is not too severe it can often be reversed by operating the bulb normally – and so cleaning the lamp –, but in excessive cases even this cannot help as the cycle will have been overstretched.

### **Cooling**

As described in the section on “Handling and operation” (page 36) tungsten halogen LV lamps above a certain wattage must be cooled to reduce the temperature at the danger points inside the pinch to below the value specified by the lamp life. The question then arises as to whether lamps can be overcooled. The answer is: in theory yes, in practice no. Forced cooling can theoretically reduce the bulb temperature sufficiently to stop the tungsten-halogen cycle, with the result that the lamp blackens. In practice, such efficient cooling is necessary that this does not occur in reasonably designed equipment.

## **End of life**

### **Filament burns out when switched on**

The life of a LV tungsten-halogen lamp ends suddenly. It does not blacken, undergoes only minor changes its other photometric and electrical data (see below for details), and suddenly the filament burns out. The life of tungsten-halogen lamps, as of all other incandescent lamps, is determined by the rate of vaporization of the tungsten in the filament. The filament does not have a constant temperature along the entire length of the wire but has small areas of higher temperature, caused either by minimal differences in thickness or by the internal structure. The rate of vaporization is higher at these points than in the surroundings, with the result that the filament becomes thinner more quickly here than elsewhere. The thinner part of the filament gets hotter, leading to a still greater increase in the rate of vaporization. This vicious circle is its downfall.

Although the vaporized filament material is returned by the tungsten-halogen cycle to the filament, it is unfortunately deposited in other – usually cooler – places. It is practically impossible to predict when the filament will burn out in a lamp operated continuously.

When lamps are switched on and off frequently it can be assumed that they will burn out on being switched on. The reason for this is clear: the filament normally goes through a period of being overheated when the lamp is switched on, and if it is already weak this can be its death blow. See also the section on “Electrical characteristics: Startup behavior”, page 28.

## Fuses

If the filament burns out, the circuit is broken and the light goes out.

In lamps operated at 24 volts or more, however, the phenomenon of the **“internal short circuit”** may occur. When the filament burns out it is broken over a very short length, which means that two ends of wire to which virtually the entire lamp voltage is applied are facing each other a very short distance apart. This gives rise to a high field strength (in volts/cm). The microatmosphere surrounding the fusion point consists of hot metal vapor. These two factors provide ideal conditions for an electric discharge or spark, which closes the break again within milliseconds.

What happens next depends on the type of lamp (single-ended or double-ended) and the electrical boundary conditions.

In single-ended lamps with a powerful current source, the electric discharge expands to fill the lamp bulb. The spark ends jump from the fusion point to the ends of the filament and melt them. The current through the lamp increases suddenly due to the negative current-voltage characteristic of the discharge. A transformation of energy takes place accordingly, and if the circuit is not broken by an external fuse the lamp bulb inevitably explodes. It is therefore extremely important to protect tungsten halogen LV lamps with a rated voltage of 24 V or more with an external fuse. See section on “Safety and standards” for fuse table (page 41).

If the current is limited by other means such as a series-connected electronic constant current unit, a fuse is not necessary.

In double-ended lamps the sequence of events when the filament burns out is initially the same. If however the filament is a long one, the electric discharge cannot always jump to the ends of the filament, but only burns between the fused ends. It does this steadily because the other parts of the filament act as a current-limiting resistance. The fact that the filament has burnt out is often not even noticed. Occasionally, if the lamp is operated without being switched for long periods of time, as the open ends of the filament gradually burn back and the electric discharge arc gets bigger, the arc may cause the bulb walls to soften. In this case the lamp “blows off” and goes out. Usually however the lamp is switched off in the normal way and then cannot be switched on again, as no spark can be ignited between the cold open ends of the filament.

There is no cure for this phenomenon, which because of filament geometry mainly affects double-ended medium and high-voltage lamps. As the current level is determined by the remaining filament and so is only increased a little, fuse protection does not prevent an electric arc forming. As however double-ended tungsten halogen LV lamps are always short and compact and so have correspondingly short filaments, an electric flashover to the ends of the filament cannot be ruled out. The effect is the same as described for single-ended lamps, so external fuse protection is also advisable for these lamps.

The electric field conditions in tungsten halogen LV lamps with operating voltages of less than 15 V are not sufficient to provoke the discharge phenomenon. They burn out, go out and stay out.

## Changes in the photometric and electrical data

If Tungsten halogen LV lamps are operated at constant wattage, the luminous flux is constant throughout their life. The bulb does not blacken. Usually however, lamps are designed to be operated at constant voltage. Because the diameter of the filament decreases slightly as a result of the vaporization of the tungsten, and because of recrystallization effects inside the filament wire, the ohmic resistance increases slightly. This reduces the wattage input of the lamp ( $U^2/R$ ) and the luminous flux. The effect is minimal and is measurable in hundredths.

The situation is reversed in lamps operated at constant current. The higher resistance increases the wattage and the lamp is a little brighter.

# Handling and operation

## Handling

Tungsten-halogen lamps are made of glass; either hard glass or quartz glass. Though glass is very tough, it can break. LV tungsten-halogen lamp bulbs are particularly robust because of their small size; nevertheless they too should be handled with the greatest care.

The point where the pins emerge from the pinch is always vulnerable, and if force is applied here, for example by attempting to bend the pins of lamps with glass bases, the pinch will inevitably break. Provided the weld between pin and foil is not also affected the lamp can usually still be operated, though the lamp body will in any case be weakened.

If possible, tungsten halogen LV lamps should only be held by the base or the pinch. If it is necessary to hold the lamp body, for example when fitting it in an appliance, any fingermarks – including invisible ones – must be cleaned off with a cloth before the lamp is switched on for the first time. A little alcohol can be used for extra thoroughness. If fingerprints are left on the glass, they burn in at high operating temperatures (between 200 and 600 °C) and cause the glass to recrystallize. This makes the glass opaque and milky and may cause the lamp to blacken and have shortened life.

When fitting lamps in lampholders, special care must be taken not to exert any shear or torque forces on the lamp or its base. Double-ended lamps must be fitted in the sprung contact socket first at one end and then at the other. It is often more difficult to remove a burnt-out lamp than to fit a new one, as the lampholder contacts may have tornished. In such cases it is advisable to replace the lampholder at the same time as the lamp, as otherwise the new lamp could suffer thermal damage (see section on "Cooling", page 36). If a lamp breaks when it is changed, all splinters must be carefully removed to avoid impairing operation of the appliance.

## Burning position

### Permitted angle of inclination

The number after the letter denoting the main burning position gives the permitted inclination from the main burning position in degrees.

### Examples of burning positions

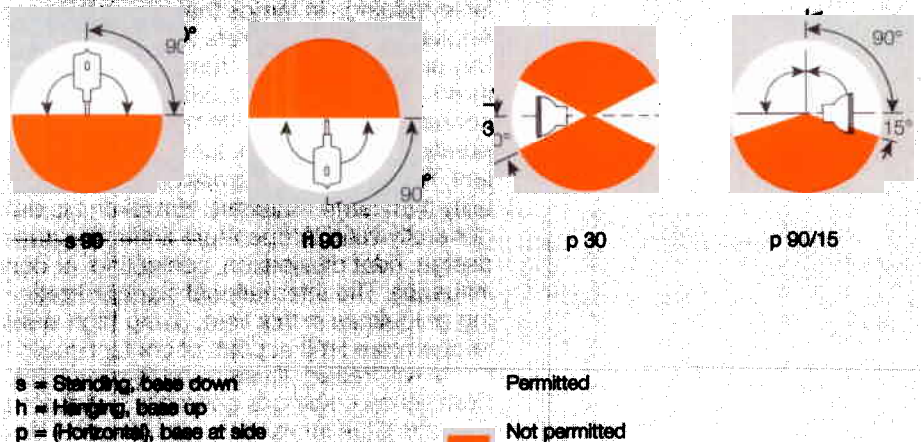

For all types of lamp, manufacturers always and standards sometimes specify a permitted range of burning positions. Fig. 33 shows some examples of this. English documentation frequently uses the terms "base up" and "base down", followed by an angle of inclination; for example "bd20" would mean the same as "s20".

It is essential that lamps are only inclined perpendicularly to the long axis of their filament. Otherwise the filament leads will be subjected to highly variable mechanical and thermal loads, with possible consequent deformation of the filament or short-circuit between filament coils

## Cooling

Tungsten-halogen lamps require a minimum temperature in order to function; however they must not be allowed to get too hot. The minimum temperature applies to the lamp bulb. Below about 200°C the tungsten-halogen cycle cannot return the deposited tungsten to the filament, and the lamp will blacken. The maximum temperature applies to the pinch. Where the molybdenum foils or lead-in wires emerge from the glass, they are exposed to oxidation from the oxygen in the air. Oxidation speeds up as the temperature increases. The oxidation process results in the hermetic seal in the quartz or hard glass being penetrated by loose metal oxide, which starts to force open the glass because of its greater volume. This could result in the lamp exploding or, more harmlessly, in the pinch simply losing its seal, oxygen penetrating the lamp bulb and the filament burning out. To prevent this, a maximum permitted pinch temperature, which must not be exceeded under any circumstances during operation, is specified for each type of lamp. As oxidation is a process that depends on temperature and time, higher temperatures can be permitted for short-life lamps than for long-life lamps. Where ambient conditions are critical, fairly low temperatures sometimes have to be maintained. The maximum permitted temperature for all lamps with a nominal life of more than 15 hours operated unprotected, in a damp environment for example, is 350°C.

The following internationally agreed values apply to lamps for photo-optical applications:

Life	Max. permitted pinch temperature
≤ 6 hours	520°C
> 6 and ≤ 15 hours	450°C
> 15 and < 300 hours	400°C
≥ 300 hours	350°C

It is important that temperature specifications genuinely relate to the temperature at the critical point: inside the pinch, at the point where the lead-in wire or molybdenum foil first makes contact with atmospheric oxygen. Precise measurement is not simple, because a measurement taken at the surface can give completely false readings in lamps that are heavily cooled.

Appliance manufacturers who are not equipped to make lamps themselves can buy suitably prepared "temperature measurement lamps" from lamp manufacturers. These have, embedded in the pinch, a thermocouple which need only be connected to a millivoltmeter. Besides the pinch temperature which is determined purely by lamp design, temperature conditions at the base pins are also important. This is because lampholder materials generally have much lower thermal stability than lamp materials. However it is difficult for lamp manufacturers to specify generally valid temperature limits, because external parameters like lampholder design, heat dissipation, contacting, or contact material have too marked an influence. The international standardization bodies are currently working on issuing guidelines in this field. Using high-quality lampholder materials, the upper temperature limit at point of contact could be 230°C, though lampholder manufacturers will frequently demand lower values.

Convection cooling is generally adequate for lamps of up to 30 watts – up to 50 watts if the lamp housing is cleverly designed. At higher wattages, forced cooling with a fan must be provided, especially if the lamp housing is very small and narrow.

If the fan fails because of a defect, the lamp circuit should also be broken, for example by means of a fitted temperature sensor switch. After-run timing relays have proved useful in preventing heat building up in the housing by continuing to operate the fan for a few minutes after the appliance has been switched off. Where reflector lamps are forcibly cooled, it is important to cool the reflector as evenly as possible; large temperature differences in the glass reflector must be avoided as they can give rise to destructive thermal stress.

## Clearance

In relation to the base geometry, the tolerances allowed for the filament position are very narrow, especially for prefocus bases (see section on "Construction of tungsten halogen low-voltage lamps: Lamp base", page 13). However, the tolerances say little or nothing about the space which the lamp bulb could occupy. As the position of the filament is the important adjustment parameter, it is quite possible for the bulb to be slightly inclined over the base.

Fig. 34 shows schematically the space which a lamp can occupy. The table gives quantitative values.

It is important for appliance designers to include a clearance around the lamp which allows for the specified tolerances. To ensure both that parts of the lamp cannot come into contact with the wall and that cooling of the bulb is not hindered, in most cases it would seem advisable to provide greater distances from the housing than the lamp's tolerances absolutely require.

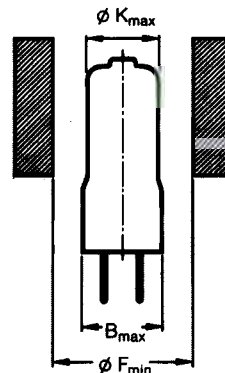

$\phi K_{max}$	$B_{max}$	$\phi F_{min}$
9	11	12
10.5	12.5	13.5
11.5	14	15
13	15	16
13.5	16	16
14	16	17
18	20	21
18.5	20	21

Dimensions in mm

$K_{max}$  = Maximum bulb diameter  
 $B_{max}$  = Maximum pinch with  
 $F_{min}$  = Minimum required clearance

34 Minimum clearance for tungsten halogen LV lamps

## Lampholder

The lampholder is the part which mates with the base. Normally it should outlive a large number of lamps, and it is therefore advisable to go for solid designs and not scrim on quality. It is always better if the pins of pin base lamps are held in sprung holders from two ends instead of pressing them against a solid part at one end.

As for bases, there are standards for the most important lampholders which define for example tolerances and minimum contact pressures. See section on "Safety and standards", page 39.

## Thermal and geometrical stability of materials

The radiation generated by incandescent lamps contains a high proportion of heat and – in the case of quartz glass lamps – a not insignificant proportion of UV. Allowance must be made for this when housing materials are selected.

At high temperatures some plastics in particular give off vaporized material which can attack the lamp surface and also attack the other components of the housing. UV radiation has a disintegrating effect which causes certain materials including glues to become brittle and crumbly with time. Caution in their use is advised.

## Optical filters

In most optical systems the heat radiated from the incandescent lamp is undesired. Thermal protection filters are frequently used to suppress it.

Two types are available: absorption filters and dichroic filters. The latter operate on the principle of interference, which is also used for cold-light reflector coatings. See section on "Construction of tungsten halogen low-voltage lamps: Reflector lamps", page 17. As these filters have no intrinsic absorption they can be used universally without any problem. Where absorption filters such as Schott "KG filters" are used, measures must be taken to ensure that these are not able to heat up excessively, or even fracture if the radiation is poorly distributed over their surface.

## Auxiliary reflectors

Auxiliary reflectors are often used to enable optical systems to use the maximum possible amount of radiation emitted by a lamp. An important example is the condenser beam path in a slide projector (Fig. 35). The light emitted to the rear is projected back into the lamp by a small spherical mirror. Lamp and mirror must be adjusted with respect to one another so that the image of the filament lies next to the actual filament. With flat-core filaments it makes sense to place the filament image above the actual filament. This gives a more or less square luminous area which fits well into the rotationally symmetrical aperture of the optical lighting system. Reproducing an image of the filament on itself must be avoided in all cases, as this would lead to overheating of the filament, increased vaporization and a shorter lamp life.

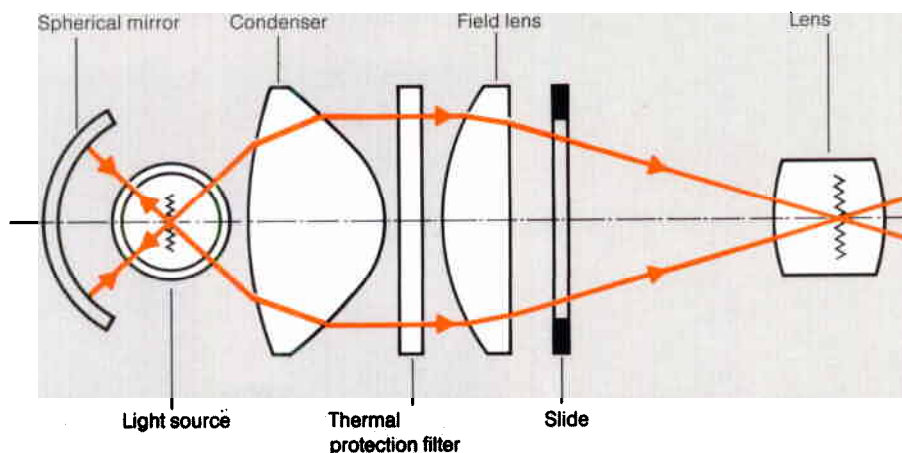

35 Beam path in a slide projector

## Choice of lamp and misuse

Tungsten halogen LV lamps are very important components of much scientific, technical, industrial and educational equipment. Although their price is often only a tiny fraction of the cost of the equipment, the correct functioning of the system as a whole often depends on them. Lamps must therefore be selected with care and good judgement.

The choice of lamp is based on the requirements dictated by the application. Factors to be considered include luminous flux, brilliance, distribution of luminous intensity, color temperature or color appearance, minimum required lamp life, operating duty cycle, vibration and mechanical shocks occurring, feasible total wattage, area to be lit, minimum or maximum beam path aperture, burning position, ambient conditions such as humidity, temperature etc.

Tungsten halogen LV lamps for photo-optics are optimized for their particular application. Changes that are useful in the context of technological development as a whole are only introduced by manufacturers very cautiously indeed for these lamps. This is intended to ensure that applications based on a particular characteristic of the lamp continue to be served in the best possible way. Where lamps designed for applications such as general lighting service or traffic and signaling are to be used for other purposes, changes suitable for those applications can make the lamp unusable in the buyer's equipment. Close contact with the lamp manufacturer before choosing a specific type of lamp is advised to protect buyers against surprises of this type.

Photo-optical equipment can have a very long service life. It is therefore important for makers of such equipment to consult with lamp manufacturers about the continued availability of the lamp of choice. As a rule, a lamp is produced for as long as demand makes it economically viable. It is therefore always preferable to choose a type manufactured in relatively large quantities for a number of photo-optical applications than an exotic special type.

## Operation in a vacuum, weightlessness

- Operating tungsten halogen LV lamps in a **vacuum** has two consequences:
- The lamp bulb becomes hotter as dissipation of heat by convection is prevented. As however most of the generated heat is given off directly in the form of radiation by the filament, in most cases the softening point of quartz glass is unlikely to be reached. There might however be an increase in the tendency of quartz glass to recrystallize, with resulting cloudiness. Tests are advisable. Hard glass lamps with their much lower melting point should not be used.
  - The lack of oxygen in the environment is beneficial. The pinch temperature (see section on "Cooling", page 36) can be much higher than the permitted level because the ends of the foils cannot oxidize.

Little experience has been gained of operation under **weightless conditions**. In theory, because of the lack of convection currents in the lamp body needed for transporting materials, the tungsten-halogen cycle will not operate. Tests have contradicted this hypothesis. Clearly the diffusion of the individual components of the gaseous atmosphere is sufficient to suppress blackening of the lamp bulb for its entire life.

## Safety and standards

### Safety

#### Risk of bursting

Most tungsten halogen LV lamps for photo-optical applications are made of quartz glass. A few types in the low wattage range are made of hard glass. The lamps are filled with an inert gas – krypton or xenon – at positive pressure to reduce the rate of vaporization of tungsten. Depending on lamp type, the pressure can rise to up to 20 bar at operating temperature.

An important quality control parameter during lamp manufacture is the burst pressure test, an integral part of the manufacturing process designed to ensure that the possibility of a lamp bursting in any conditions that might arise in practice is virtually ruled out.

There remains nevertheless a residual risk which can naturally be increased by incorrect operating conditions such as excessive temperature, mechanical stress or lack of a fuse. Housing designers are therefore well advised to take suitable precautions for the event of a lamp bursting.

These include only operating lamps in enclosed housings which effectively prevent hot bulb splinters from flying away.

#### Temperature

Tungsten halogen LV lamps attain surface temperatures of up to 900°C during operation, and even more in extreme cases.

The lamps must not be touched while they are lit. The cooling period can easily extend to a quarter of an hour, depending on lamp wattage and housing design. Housing manufacturers should carry out tests to ascertain the time after which the bulb temperature falls below 60°C. Only then is it safe to hold the lamp. Users must be informed about this with appropriate warnings.

#### Glare

Tungsten halogen LV lamps for photo-optical applications can attain average brilliance values of up to 3000 cd/cm<sup>2</sup> in the filament field. Glare cannot be ruled out. Ideally, the lamp housing should be designed so that the lamp cannot be viewed with the naked eye.

#### UV radiation

Tungsten halogen LV lamps with **quartz glass** bulbs emit about 0.2% to 0.3% of the electrical power they consume in the form of radiation below 380 nm, depending of course on their color temperature.

A hazard from the UV part of the radiation cannot be ruled out, especially from high-wattage lamps.

At an unfiltered illuminance of 10,000 lux, the erythema threshold (first reddening of the skin) is reached in 90 minutes with a color temperature of 3000 K.

Where necessary, users of an appliance must be suitably protected against the dangers of UV radiation, for example with filters.

**Hard glass** lamps emit virtually no radiation below 315 nm, the border between UV-A and UV-B. The proportion of UV-A may represent up to 0.2% of the electrical power consumed.

# Standards

## General standards

DIN 5031	Optical radiation physics and photometrics
DIN 5032	Measuring light
DIN 5033	Measuring color
DIN 5039	Light, lamps, luminaires; terminology and classification
DIN 6169	Color rendering
DIN 6173	Color matching
DIN 19040-7	Photographic terminology
DIN 40080 IEC 410 ISO 2589 MIL Standard 105D	Procedures and tables for testing random samples using qualitative characteristics (attribute testing)

## Lamp standards

IEC 357 DIN EN 60357	Tungsten halogen lamps (non vehicle)
IEC 434	Aircraft electrical filament lamps
IEC 682 DIN IEC 682	Standard method of measuring the pinch temperature of quartz tungsten-halogen lamps
IEC 887 DIN IEC 887	Glass bulb designation system for lamps
IEC 61-1 DIN 49640	Lampcaps
IEC 61-2 DIN 49462	Lampholders
IEC 838 DIN VDE 0616	Miscellaneous lampholders
IEC 34B DIN 49648	International designation of lampcaps and -holders

## Appliance standards

IEC 598-1 EN 60598-1 DIN VDE 0711/1	Luminaires: General requirements and tests
IEC 598-2-4 EN 60598-2-4 DIN VDE 0711/204	Portable general purpose luminaires
IEC 598-2-6 EN 60598-2-6 DIN VDE 0711/206	Luminaires with built-in transformers for filament lamps
IEC 598-2-9 EN 60598-2-9	Photo and film luminaires (non-professional)
IEC 598-2-17 EN 60598-2-17 DIN VDE 0711/217	Luminaires for stage lighting, television, film and photographic studios (outdoor and indoor)
IEC 335-2-56 EN 60335-2-56 DIN VDE 0700	Particular requirements for projectors and similar appliances
DIN 15560	Spotlights for film, television, stage and photography

## Special safety standards

IEC 432 EN 60432 DIN VDE 0715/1	Safety requirements for tungsten filament lamps for domestic and similar general lighting purpose
IEC 335-1 EN 60335-1 VDE 0700/1	Safety of household and similar electrical appliances; general requirements
DIN 19090/1	Projection equipment; terminology, assignment of safety requirements
DIN 19090/2	Projection equipment; safety requirements for film projectors and film projection systems
DIN 19090/3	Projection equipment; safety requirements for film sound equipment and systems

## Standard lamps

Tungsten halogen LV lamps are very versatile. Some types are also suitable as secondary standards for photometric variables such as luminous flux, luminous intensity etc.

To produce such a standard, several lamps of a selected type are operated over a period of hours and the relevant photometric data recorded. The most stable examples are then calibrated with scientific standard lamps. The secondary standards produced in this way are best operated at a voltage slightly less than the rated voltage to achieve constant radiation over a long period of time.

Calibration is performed by the Physikalisch Technische Bundesanstalt (PTB) in Braunschweig/Brunswick (Germany) or by the OSRAM photometric laboratory.

## Fuse table

Tungsten halogen LV lamps for rated voltages of less than 24 V do not require an external fuse in the circuit.

All other single-ended lamps must have a fuse. The safety values listed here have not yet all been incorporated in the standards.

Voltage (Volts)	Wattage (Watts)	Fuse (Amperes)
24	20	2
24	50	4
24	75	6.3
24	100	6.3
24	150	10
24	250	16
36	400	16

Quick-blow 250 V fuses with high breaking capacity (IEC127) should be used.

To complete the picture, the safety values for medium and high-voltage lamps (floodlights) are also given.

Quick-blow 250 V fuses with high breaking capacity should be used.

Those marked \*: quick-blow 500 V D-type fuse (IEC 241).

Voltage (Volts)	Wattage (Watts)	Fuse (Amperes)
100 ... 135	150	2
200 ... 250	150	2
100 ... 135	200	4
<del>200 ... 250</del>	<del>200</del>	2
100 ... 135	300	4
200 ... 250	300	2
100 ... 135	500	6.3
200 ... 250	500	4
100 ... 135	750	10
200 ... 250	750	6.3 6.0*
100 ... 135	1000	10
200 ... 250	1000	6.3 6.0*
100 ... 135	1500	20*
200 ... 250	1500	10*
100 ... 135	2000	25*
200 ... 250	2000	10*
100 ... 135	10000	100*
200 ... 250	10000	50*

## Base table

Schematic drawings of the most important lamp bases commonly used for tungsten halogen LV lamps are shown in Fig. 36 to enable ready identification. The relevant standards, given under the base designations in the illustration, contain more detailed specifications. Lamp manufacturers provide technical data for as yet unstandardized bases.

The most important base types are:

G4  
GY4  
GZ4  
GZX4  
G5.3  
GX5.3  
G5.3-4.8  
G6.35  
GY6.35  
GZ6.35  
G9.5  
GY9.5

R7s  
RX7s

PG22-6.35

PK30d  
PKX30d

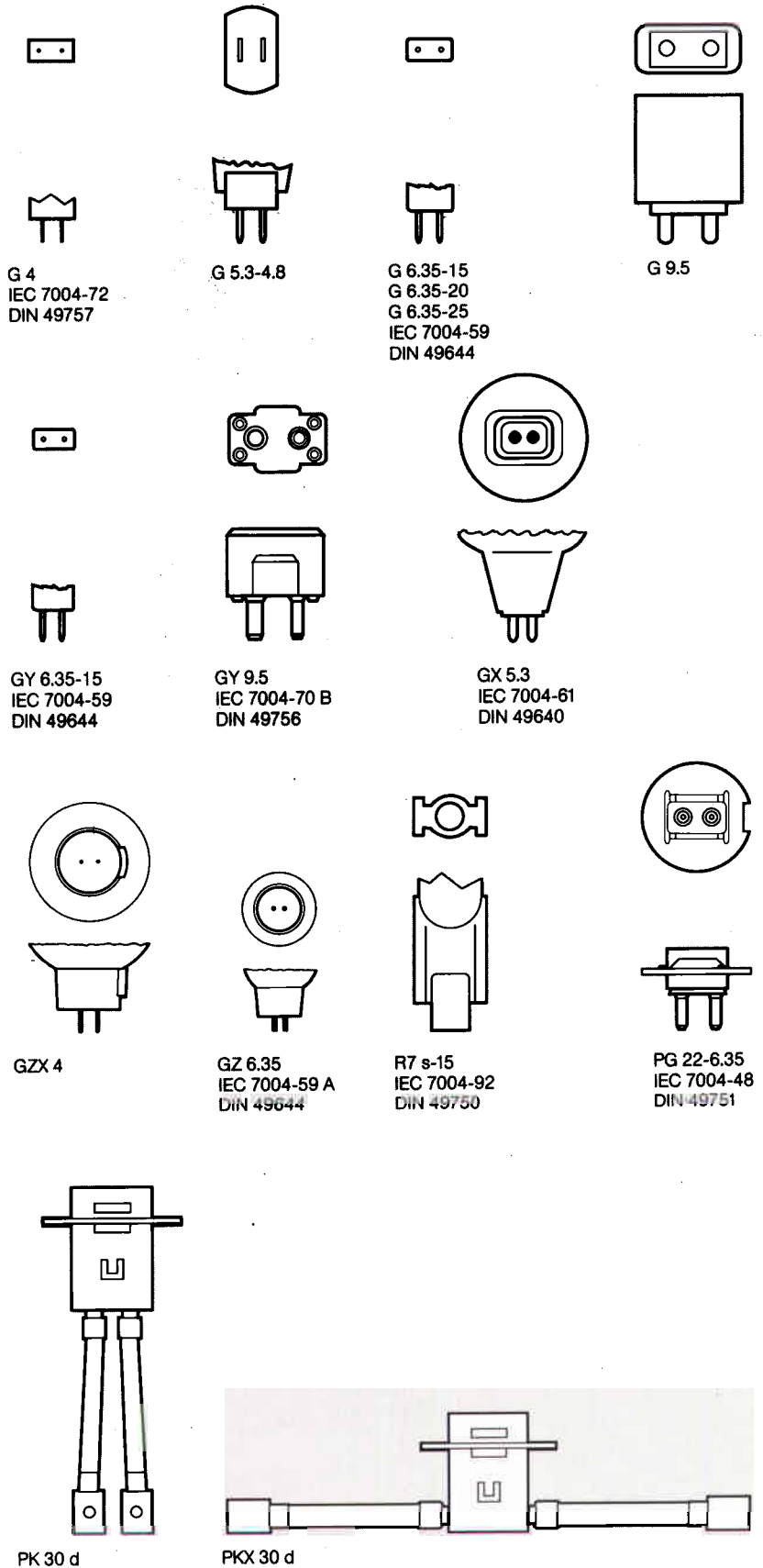

36 Schematic drawings of the most important lamp bases

**A**

Absorption filter	37
Airfield lamps	30
AQL	32
Axial filament	10

**B**

Base	13, 16, 42
Base designation	14
Base temperature	36
Battery operation	31
Black body radiator	5
Blue reflector	18
Brilliance	21, 22
Bulb temperature	26, 36
Burning out	33
Burning position	35
Bursting, risk of	39

**C**

Carbon filament	4
Cement-free base	14
Ceramic base	13
Clearance	37
Coating, types of	18
Coil geometry	9
Cold-light reflector	18
Collimating reflector	17
Color rendering index	21, 25
Color temperature	5, 21, 24
Rated current operation	30
Rated voltage operation	30
Contact pins	13
Convection cooling	36
Cooling	33, 36
Covered filament	11

**D**

Daylight spectrum	23
Designation system	14
Dichroic reflector	18
Dimensioning of lamps	19
Dimming	26, 32
Discharge	34
Doping	4
Double filament	11
Double-ended lamps	8, 10, 13, 19

**E**

Electrical data	28, 34
Ellipsoidal reflector	17
Erythema threshold	39
Evaporation, rate of	8, 33
Exhaust tube	8
Expansion coefficient	12
Eye sensitivity curve	20
Eye, sensitivity of	20

**F**

Facetted reflector	17
Filament	4, 9
Filament axis	10
Filament geometry	9, 19
Filler gas	7
Filters	37
Flashing operation	33
Flat-core filament	11

Focusing reflector	17
Foil seal	12
Foils	12
Frosting	8
Fuse protection	30
Fuses	34, 41

**G**

Generation of light	4
Glare	39
Glass base	13
Glass reflector	17

**H**

Halogen	6
Handling lamps	35
Hard glass	8, 12, 24

**I**

Incandescent emitter	4
Incandescent filament	4
Incandescent lamp spectrum	23
Infrared radiation	4, 18, 23
Internal short circuit	34

**K**

Krypton	6
---------	---

**L**

Lamp base	13
Lamp bulb	8
Lamp geometry	19
Lamp laws	21
Lamp life	32
Lamp temperatures	6, 26, 29
Lamp holder	37
Lead-in wires	8
Light center length	19
Luminous efficacy	21, 22
Luminous flux	21
Luminous intensity	21

**M**

Maintenance	32, 34
Melting point	4
Metal base	13
Metal reflector	17
Minimum clearance	37
Modulated filament	11
Modulation of light	28
Molybdenum foils	12
Mounting distance	17, 20
MR 11, MR 16	16

**O**

Operation cycle	30
Optical filters	37
Overvoltage operation	32

**P**

Parabolic reflector	17
Phase-shift control	31
Photometric characteristics	20
Photometric data	34
Photometric units	21
Pinch	8, 36
Pinch temperature	36

Planckian radiator	5, 23, 25
Prefocus base	14
Premature failure	32
Primary coil	11

**Q**

Quartz glass	8, 12, 24
--------------	-----------

**R**

Radiation balance	4
Recrystallization	34, 35
Rectangular filament	9
Reflectivity	18
Reflector lamps	16
Round-core filament	10

**S**

Safety	39
Sealing techniques	12
Secondary coil	11
Segmented filament	11
Series operation	31
Simmering	33
Single-ended lamps	8, 10, 13, 19
Spectrum	23
Square filament	11
Standard lamps	41
Standards	40
Startup behavior	28
Switch-off behavior	27
Switching frequency	33

**T**

Temperature measurement lamp	36
Thermal protection filter	37
Thermal radiation	4
Thermal radiator	4
Thermal stability	37
Transverse filament	10
True temperature	5
Tungsten	4, 5
Tungsten-halogen cycle	6, 26, 33

**U**

UV radiation	39
UV reflector	18

**V**

V-lambda curve	20
Vacuum	39
Vapor pressure	4

**W**

Weightlessness	39
Wire dimensions	9

**X**

XENOPHOT®- lamps	7
------------------	---

**For Orders and General Information**

---

**USA**

OSRAM SYLVANIA Inc.  
National Customer Support Center  
18725 N. Union Street, Westfield, IN 46074  
Display/Optic  
Phone: 888/677-2627 Fax: 800/762-7192  
888/OSRAMCS

**Canada**

OSRAM SYLVANIA, LTD.  
2001 Drew Road, Mississauga, Ontario, L5S 1S4  
**National Customer Service**  
Phone: 800/265-BULB Fax: 800/667-6772

---

**Headquarters**

OSRAM SYLVANIA Inc.  
100 Endicott Street  
Danvers, MA 01923

OSRAM SYLVANIA, LTD.  
2001 Drew Road  
Mississauga, Ontario, L5S 1S4

[www.sylvania.com](http://www.sylvania.com)  
[www.osram.com](http://www.osram.com)  
[www.osram.de](http://www.osram.de)

Copyright OSRAM SYLVANIA Inc. 2000

?? 6/97 SI Subject to modification without notice

**THERE IS LIGHT. AND THERE IS OSRAM.**

**OSRAM**